

HUM ELIT OIL

PUMPING EQUIPMENT

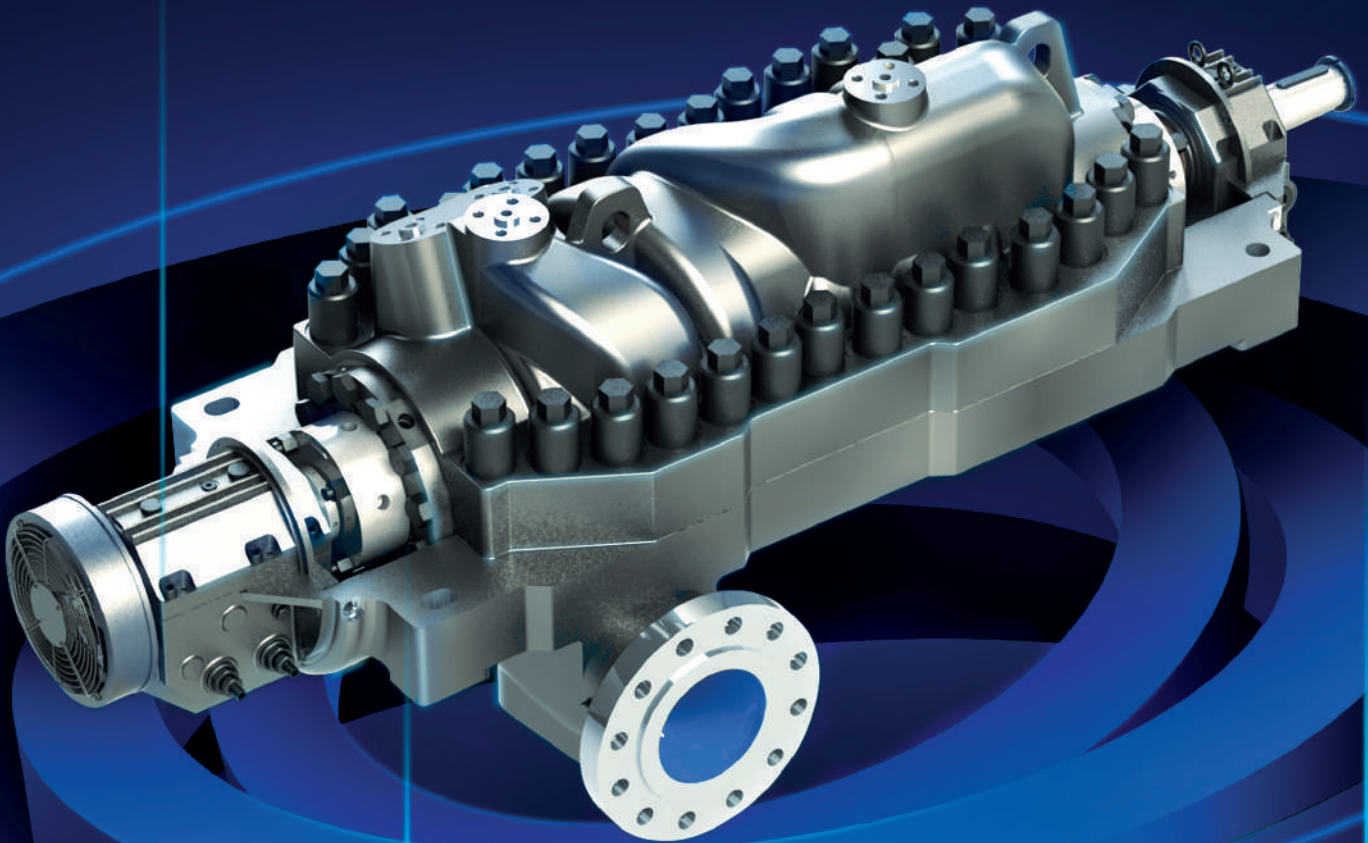



HUM ELIT OIL

CENTRIFUGAL PUMPS

Licensed by
JSC "NASOENERGOMASH SUMY"

PE Series Multistage Segmental /Radially Split Barrel



PE 720

Designed for delivering treated water (feed water) into stationary steam boilers of the conventional (fossil-fueled) thermal power stations as well as to supply feedwater into waste-heat boilers at the power stations with combined-cycle and steam power plants.

Motor driven horizontal multistage diffuser centrifugal pumps of segmental or barrel type with a withdrawable cartridge of ring-section type. Single flow impeller arrangement, with all the impellers facing the same way. May be operated both at the constant and variable speed of rotation.

The pump rotor is carried by the oil-ring or pressure lubricated plain bearings.

Shaft sealing: packed glands or mechanical seals.

At the Customer's request, the following options can be provided:

- such a construction of studs for casing main joint that enables the use of hydraulic jacks (wrenches) for pre-tensioning the studs by making them only elongate before nuts screwing-on, thus avoiding torsional stresses arisen and ensuring their accurate and even tightening-up;
- equipping with a balance disc-from-seat separation device to ensure the guaranteed axial gap in the balancing device, thus holding pump rotor unbound both during standstill and at start-ups.

Nos	Pump make	Capacity, m ³ /h	Head, m	Rotational speed (synchr.), rpm	Motor nominal power, kW
1	PE 20-16	20	172	3000	30
2	PE 50-70	35	530	3000	160
3	PE 63-90	60	930	3000	250
4	PE 65-28	65	290	2900	110
5	PE 65-40	65	440	3000	132
6	PE 65-40	25	480	3000	110
7	PE 65-40-1	51	425	3000	132
8	PE 65-40-1	65	580	3000	200
9	PE 65-40-1	70	501	3000	160
10	PE 65-40-1	80	580	3000	250
11	PE 65-53	65	580	3000	200
12	PE 65-53	54.14	617.83	3000	200
13	PE 65-53	51.7	615.4	3000	200
14	PE 65-53	80	500	3000	200
15	PE 90-110	90	1100	3000	500
16	PE 90-110	100	1100	3000	500
17	PE 90-180	90	1900	3000	1000
18	PE 100-32	100	330	3000	160
19	PE 100-53	80	580	3000	315
20	PE 145-30	145	293	3000	200
21	PE 150-53	150	580	3000	500
22	PE 150-63	150	700	3000	500
23	PE 160-140	160	1400	3000	1000
24	PE180-80	180	887	3000	630
25	PE 180-140	180	1450	2900	1000
26	PE 240-105	240	1140	3000	1250
27	PE 240-110	240	1210	3000	1250
28	APE 260-100	260	960	3000	1000
29	PE 250-190	250	1950	3000	2000
30	PE 270-150-3	270	1650	3000	2000
31	PE 270-150-4	250	1850	3000	2000
32	PE 270-150-4	248	1524	3000	1600
33	PE 275-100	275	1100	2970	1250
34	PE 310-100	310	1100	3000	2000
35	PE 310-110	310	1200	3000	2000
36	PE 310-140	310	1550	3000	2000
37	PE 310-160	310	1750	3000	2000
38	PE 315-130	315	1394	3000	1600
39	PE 315-140	315	1520	3000	2000
40	PE 315-150	315	1647	3000	2000
41	PE 315-175	315	1900	3000	2500
42	PE 350-45	350	460	3000	630
43	PE 380-185-5	380	2030	3000	3150

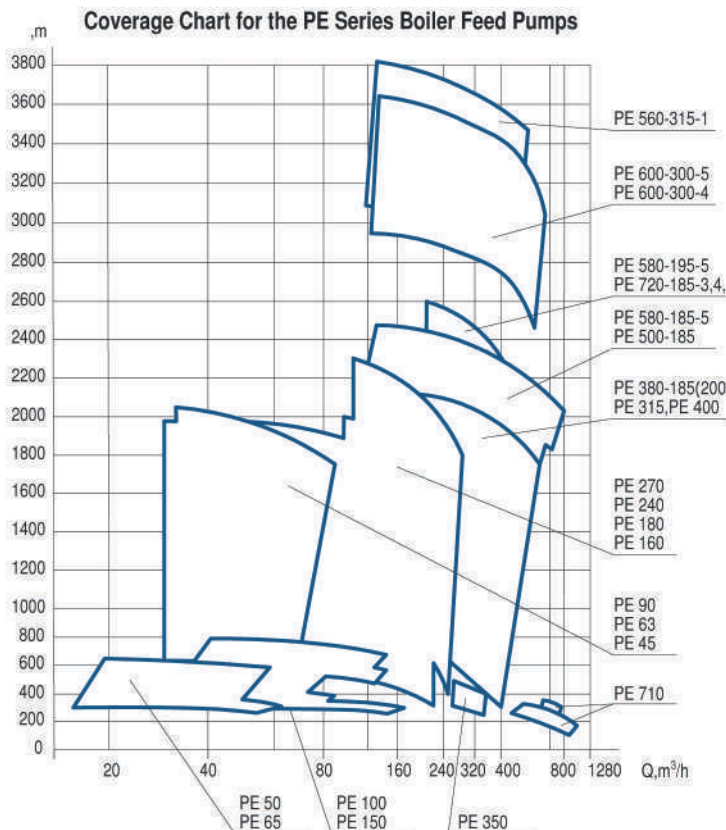

PE Series Multistage Segmental /Radially Split Barrel

Nos	Pump make	Capacity, m ³ /h	Head, m	Rotational speed (synchr.), rpm	Motor nominal power, kW
44	PE 380-200-5	380	2190	3000	3150
45	PE 400-185	400	1900	3000	3150
46	PE 500-180-5	500	1950	3000	4000
47	PE 560-315-1	560	3500	6000	8000
48	PE 580-185-5	580	2030	3000	4000
49	PE 580-195-5	580	2150	3000	5000
50	PE 600-300-4	600	3290	6300	8000
51	PE 600-300-5	600	3290	6300	8000
52	PE 640-360	640	3670	6000	7000
53	PE 710-280	710	280	3000	800
54	PE 720-185-3	720	2030	3000	5000
55	PE 720-185-4	780	2030	4500	6300
56	PE 720-185-4	735	2030	3000	6300
57	PE 720-185-4	740	2250	3000	6300
58	PE 720-185-4	872	2052	3000	6300
59	PE 720-185-6	720	2030	3000	5000
60	PE 720-185-7	720	2030	3000	5000



PE 400



PE 150

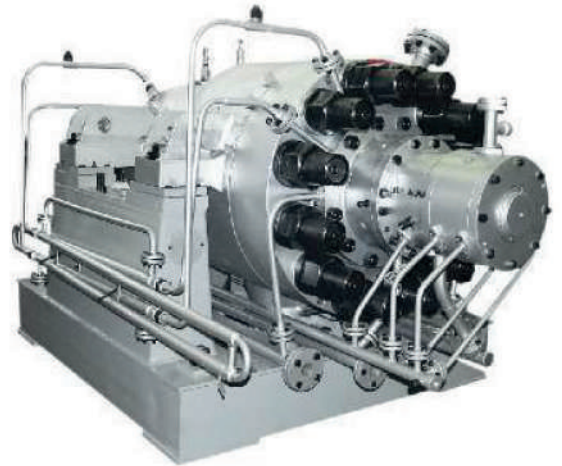

PE 600

MG and MGL Fluid Couplings

Nos	Fluid coupling make	Output shaft speed range, rpm		Power transmitted by the coupling, kW
		from	t	
1	MG-600	2900	600	2000
2	MG-670	2900	600	5000
3	MGL-M-710	6300	1900	7000
4	MG2-600	2900	600	5000
5	MG2L-650	2900	600	7000

Designed for controlling the rotational speed of electrically driven pumping sets in order to vary their head and capacity to meet the system requirements.

The scoop-controlled horizontal hydrodynamic couplings are made in single-chamber version with an integral gear (MGL-M-710) or without it (MG 600 and MG 670) and in double-chamber version (MG2-600 and MG2L-650).



MG 600



MGL-M-710

PD Series Double Flow Axially / Radially Split

The boiler feed booster pumps are installed upstream of boiler feed pumps to deliver feed water with the pumping temperature of max. 165°C at the power units in TPS's to ensure a cavitation-free operation of the main pumps.

PD.650-160: motor-driven horizontal single-stage axially split (radially split in case of PD 650-160-2) volute-casing centrifugal pumps with a double entry radial impeller. Pump nozzles oriented horizontally to the opposite sides. The pump rotor is carried by the oil-ring lubricated plain bearings. Shaft sealing: packed glands.

PD 1600-180-2: turbine-driven horizontal single-stage radially split volute-casing centrifugal pumps with a double entry radial impeller. The discharge nozzle horizontally sideward, the suction nozzle vertically to the bottom. The pump rotor is carried by the pressure lubricated plain bearings. Shaft sealing: mechanical seals.



PD

Nos	Pump make	Capacity, m ³ /h	Head, m	Rotational speed, rpm	Motor nominal power, kW
1	PD 650-160	650	158	3000 (synchr.)	324
2	PD 650-160-2	650	158	3000	303
3	PD 1600-180-2*	1660	194	2100	954
4	PD 1600-180-2 **	1050	184	2100	633
5	PD 1600-180-2 ***	1240	158	2000	618

* for TPS 800 MW power units

** for TPS 500 MW power units

*** for TPS 320 MW power units

Coverage Chart for the Boiler Feed Booster Pumps PD

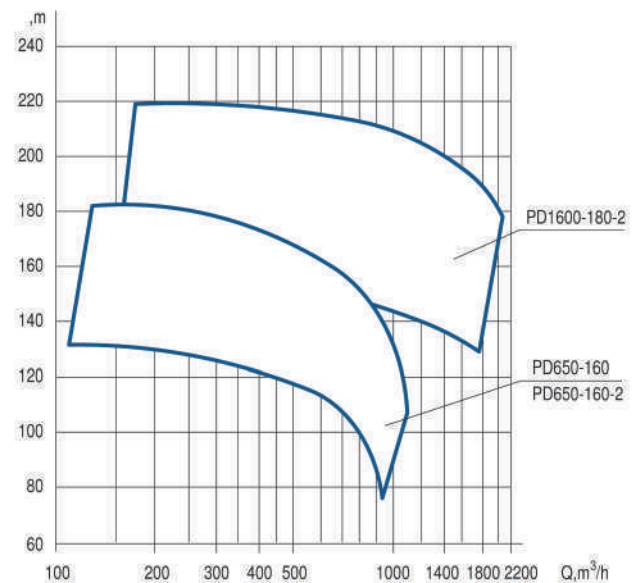

CNSg & CNSgM Series Multistage Segmental



CNSg

Designed for handling water in hot water heating and water supply systems of industrial projects and public utilities (including the delivery of feedwater into the small-size boilers).

Electrically driven horizontal ring-section multistage centrifugal pumps. The pump rotor is carried by the grease-lubricated antifriction bearings. Shaft sealing: packed glands

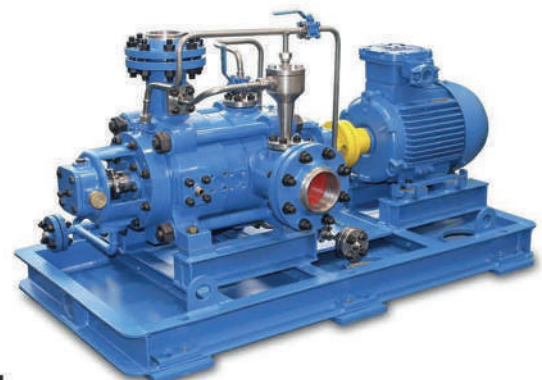

CNSgM

CNSg & CNSgM Series Multistage Segmental

Nos	Pump make	Capacity, m ³ /h	Head, m	Rotational speed (synchr.), rpm	Motor nominal power, kW
1	CNSg 16-68	16	68	3000	7.5 (11)
2	CNSg 16-102	16	102	3000	11
3	CNSg 16-136	16	136	3000	15
4	CNSg 16-170	16	170	3000	18,5
5	CNSg 16-204	16	204	3000	22
6	CNSg 16-238	16	238	3000	30
7	CNSg 16-272	16	272	3000	30
8	CNSg 16-306	16	306	3000	37
9	CNSg 16-340	16	340	3000	37
10	CNSgM 38-44	38	44	3000	11
11	CNSgl 38-66	38	66	3000	15
12	CNSgl 38-88	38	88	3000	22
13	CNSgl 38-110	38	110	3000	22
14	CNSgl 38-132	38	132	3000	22
15	CNSgl 38-154	38	154	3000	30
16	CNSgl 38-176	38	176	3000	30
17	CNSgl 38-198	38	198	3000	37 (55)
18	CNSgl 38-220	38	220	3000	37 (55)
19	CNSgl 60-66	60	66	3000	22
20	CNSg 60-99	60	99	3000	30
21	CNSg 60-132	60	132	3000	55
22	CNSg 60-165	60	165	3000	55
23	CNSg 60-198	60	198	3000	55
24	CNSg 60-231	60	231	3000	75
25	CNSg 60-264	60	264	3000	75
26	CNSg 60-297	60	297	3000	110
27	CNSg 60-330	60	330	3000	110
28	CNSg 38-44	38	44	3000	11
29	CNSg 38-66	38	66	3000	15
30	CNSg 38-88	38	88	3000	18.5
31	CNSg 38-110	38	110	3000	22
32	CNSg 38-132	38	132	3000	30

Nos	Pump make	Capacity, m ³ /h	Head, m	Rotational speed (synchr.), rpm	Motor nominal power, kW
33	CNSg 38-154	38	154	3000	30
34	CNSg 38-176	38	176	3000	30
35	CNSg 38-198	38	198	3000	37
36	CNSg 38-220	38	220	3000	45
37	CNSg 60-66	60	66	3000	22
38	CNSg 60-99	60	99	3000	30
39	CNSg 60-132	60	132	3000	45
40	CNSg 60-165	60	165	3000	55
41	CNSg 60-198	60	198	3000	55
42	CNSg 60-231	60	231	3000	75
43	CNSg 60-264	60	264	3000	75
44	CNSg 60-297	60	297	3000	90
45	CNSg 60-330	60	330	3000	110
46	CNSg 38-44-01*	38	44	3000	11
47	CNSg 38-66-01*	38	66	3000	15
48	CNSg 38-88-01*	38	88	3000	18.5
49	CNSg 38-110-01*	38	110	3000	22
50	CNSg 38-132-01*	38	132	3000	30
51	CNSg 38-154-01*	38	154	3000	30
52	CNSg 38-176-01*	38	176	3000	30
53	CNSg 38-198-01*	38	198	3000	37
54	CNSg 38-220-01*	38	220	3000	45
55	CNSg 60-66-01*	60	66	3000	22
56	CNSg 60-99/4	27	25	1500	4
57	CNSg 60-99-01*	60	99	3000	30
58	CNSg 60-132-01*	60	132	3000	45
59	CNSg 60-165-01*	60	165	3000	55
60	CNSg 60-198-01*	60	198	2940	55
61	CNSg 60-231-01*	60	231	3000	75
62	CNSg 60-264-01*	60	264	3000	75
63	CNSg 60-297-01*	60	297	3000	90
64	CNSg 60-330-01*	60	330	3000	110

Explosion-proof version

Coverage Chart for the Boiler Feed Pumps CNSg and CNSgM

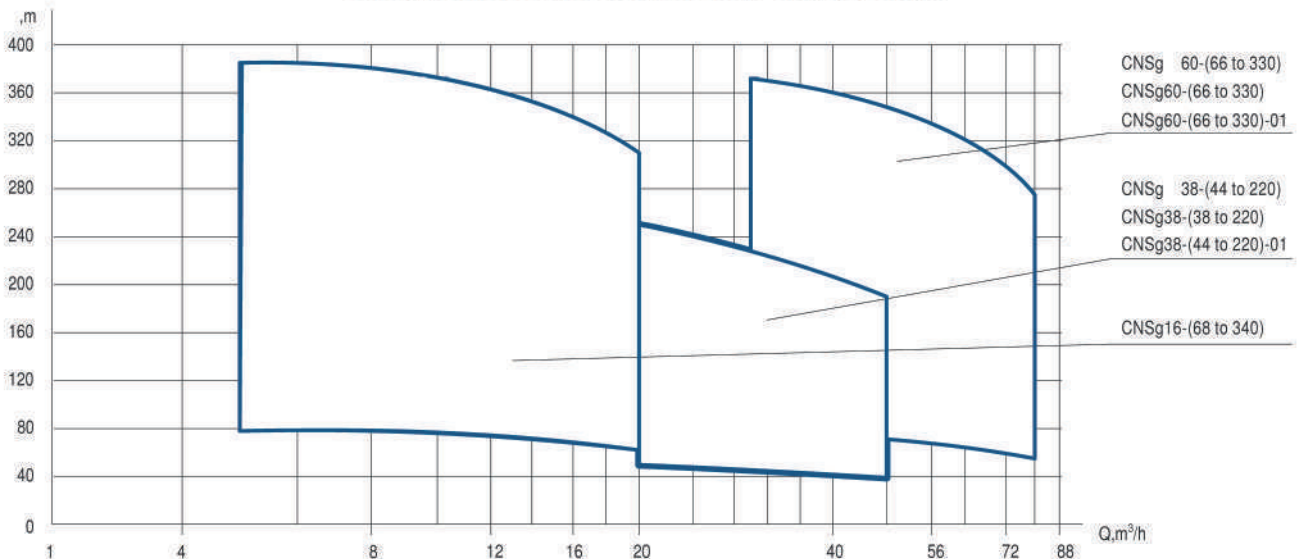

SE Series Double Flow Axially Split



SE 1250-70



SE 1250-140-11

Installed in main plants for hot water circulation in the heating circuit systems within a whole district

Electrically driven horizontal single stage or two-stage (with an interstage crossover for SE 800-100-11, SE 1250-140-11) axially split volute process centrifugal pumps between bearings, with one or two (in case of two-stage pumps) double entry radial impellers. Semicenterline casing support. The pump rotor is carried by the oil-ring or pressure lubricated plain or antifriction bearings. Shaft sealing: packed glands or mechanical seals.

SE

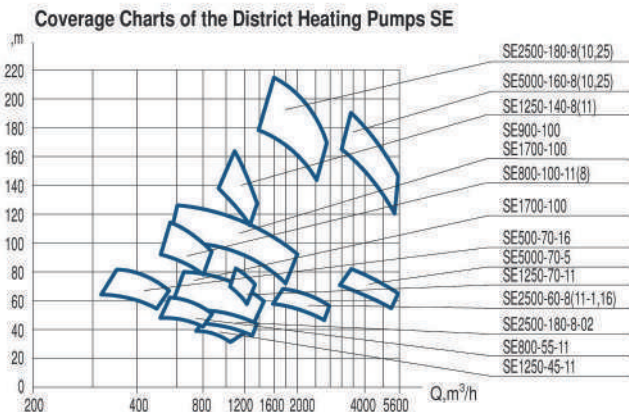

Nos	Pump make	Capacity, m³/h	Head, m	Rotational speed (synchr.), rpm	Motor nominal power, kW
1	SE 500-70-16	500	70	3000	160
2	SE 800-55-11	800	55	1500	200
3	SE 800-100-8	800	100	3000	315
4	SE 800-100-11	800	100	1500	315
5	SE 900-100	900	100	3000	250
6	SE 1250-45-11	1500	45	1500	200
7	SE 1250-70-11	1250	70	1500	315
8	SE 1250-140-8	1250	140	3000	800
9	SE 1250-140-11	1250	140	1500	630
11	SE 1700-100	1500	70	1500	600
10	SE 1700-100	1700	110	1500	600
12	SE 2500-60-8	2500	60	1500	630
13	SE 2500-60-11-1	2500	60	1500	630
14	SE 2500-60-16	2500	60	1500	630
15	SE 2500-160-8	2500	160	1500	1600
16	SE 2500-180-8	2500	180	3000	1600
17	SE 2500-180-8-02	1250	45	1500	250
18	SE 2500-180-10	2500	180	3000	1600
19	SE 2500-180-25	2500	180	3000	1600
20	SE 5000-70-5	5000	70	1500	1250
21	SE 5000-160-8	5000	160	3000	3150
22	SE 5000-160-10	5000	160	3000	3150
23	SE 5000-160-25	5000	160	3000	3150

Ks /Ksg Series Inducer Horizontal Segmental, Between Bearings & KsV Series Vertical Can/Barrel, Diffuser

Nos	Pump make	Capacity, m ³ /h	Head, m	Rotational speed (synchr.), rpm	Motor nominal power, kW
1	Ks 32-150-2	32	150	3000	22
2	Ks 50-55-2	50	55	3000	15
3	Ks 50-110-2	50	110	3000	30
4	Ks 80-155-2	80	155	3000	55
5	KsV 90-155	90	155	3000	75
6	KsV 90-220	90	220	3000	110
7	KsV 120-85	120	85	3000	55
8	KsV 125-55-2	125	55	3000	30
9	KsV 125-55-2	125	45	3000	30
10	KsV 125-55-2	125	40	3000	30
11	KsV 125-55-2	125	70	3000	30
12	KsV 125-55-2.4	125	55	3000	30
13	KsV 125-55a-2.4	125	45	3000	30
14	KsV 125-556-2.4	125	40	3000	30
15	KsV 125-140-1	125	140	3000	75
16	KsV 125-140-2	125	140	3000	75
17	KsV 125-140-2	125	125	3000	75
18	KsV 125-140-2	125	100	3000	55
19	KsV 125-140-2.4	125	140	3000	75
20	KsV 125-140a-2.4	125	125	3000	75
21	KsV 125-1406-2.4	125	100	3000	55
22	KsV 200-130	200	130	3000	110
23	KsV 200-130	200	115	3000	110
24	KsV 200-130	200	99	3000	110
25	KsV 200-220	200	220	1500	250
26	KsV 200-220	145	203.4	1500	132
27	KsV 200-220	200	180	1500	250
28	KsV 200-220	150	180	1500	132
29	KsV 200-220	180	220	1500	250
30	KsV 200-220	200	190	1500	160
31	KsV 200-220-1	200	220	1500	250
32	KsV 285-260	336	260	1500	400
33	KsV 285-260-1	335	238	1500	400
34	KsV 300-70	230	70	1000	75
35	KsV 320-85	320	85	1500	132
36	KsV 320-85	200	100	1500	132
37	KsV 320-125	320	125	1500	160
38	KsV 320-50/160	320	50/160	1500	315
39	KsV 320-160-2	320	160/100	1500	250
40	KsV 320-160-3	320	160/100	1500	250
41	KsV 320-160-4	320	160/100	1500	250
42	KsV 500-85-1	500	85	1000	200
43	KsV 500-85-1	475	115	1000	250
44	KsV 500-150-1	500	150	1500	315
45	KsV 500-220-1	500	220	1500	500
46	KsV 700-180	700	180	1500	500
47	KsV 700-210	700	210	1500	630
48	KsV 1000-95	1000	95	1000	400
49	KsV 1150-90	1150	90	1500	500
50	KsV 1150-90	925	90	1500	500
51	KsV 1250-45	1250	45	1500	250
52	KsV 1250-45	975	45	1500	250
53	KsV 1500-140	1500	140	1500	100
54	Ks 1500-240-2	1500	240	3000	1250
55	KsV 1600-90	1000	90	1000	630
56	Ksg 80-155-6	80	155	2940	55

Used for pumping condensate in the steam and water circuit systems of the thermal power stations that burn organic fuel and to transfer water in heating plants and water supply systems.

Ks /Ksg: Electrically driven horizontal single-stage (Ks 50-55-2) or multistage ring section centrifugal pumps between bearings, with inducer and single entry impeller or impellers arranged one behind the other. Rotor axial thrust balancing by drum. The pump rotor is carried by the antifriction bearings (medium-lubricated internal plain bearings in case of Ksg pump). Rotor axial thrust balancing by balance disc and balance disc seat. Shaft sealing: packed glands or mechanical seals

Ks 1500-240-2: horizontal centerline-mounted, single-stage axially split volute casing centrifugal pump with a double entry impeller and horizontal nozzles located opposite inline.

Radial forces and the residual rotor axial thrust are absorbed by forced oil lubricated plain bearings (one segmental thrust bearing and two radial bearings).

Shaft sealing: by single mechanical seals

KsV: Electrically driven vertically suspended can diffuser single-stage (KsV 125-55 and KsV 1250-45) or multistage inducer pumps with single flow impeller arrangement (except KsV 200-130, KsV 1150-90, KsV 1250-45 pumps equipped with a double suction first stage impeller). The inner casing (a withdrawable rotating assembly) of ring-section type comprises a bare rotor, casing parts, a shaft seal (packed gland or mechanical seal) and bearings.



Ks



KsV

KO, 2KO & 3KO Series End Suction, with Overhung Impeller

KO



Used for pumping condensate in the steam and water circuit systems of the thermal power stations that burn organic fuel and to transfer water in heating plants and water supply systems.

Flexibly coupled, electrically driven horizontal foot-mounted single-stage (KO), double-stage (2KO) or three-stage (3KO) end suction volute-casing centrifugal pumps with overhung impeller(s) and bearing bracket. The pump rotor is carried by grease-lubricated antifriction bearings. Shaft sealing: by a soft-packed gland or a mechanical seal.

Nos	Pump make	Capacity, m ³ /h	Head, m	Rotational speed (synchr.), rpm	Motor nominal power, kW
1	KO 50/56	50	56	3000	15
2	KO 50/56	50	48	3000	15
3	KO 50/56	50	41	3000	15
4	2KO 50/112	50	112	3000	30
5	2KO 50/112	50	97	3000	30
6	2KO 50/112	50	80	3000	30
7	3KO32/150	32	150	3000	30

KOSH & 2KOSH Series Inducer End Suction, with Overhung Impeller

KOSH



Used for pumping condensate in the steam and water circuit systems of the thermal power stations that burn organic fuel and to transfer water in heating plants and water supply systems.

Flexibly coupled, electrically driven horizontal foot-mounted single-stage (KOSH) or double-stage (2KOSH) end suction volute-casing centrifugal pumps with an inducer, overhung impeller(s) and bearing bracket. The pump rotor is carried by grease-lubricated anti-friction bearings. Shaft sealing: by a soft-packed gland or a mechanical seal.

Nos	Pump make	Capacity, m ³ /h	Head, m	Rotational speed (synchr.), rpm	Motor nominal power, kW
1	KOSH 80-200	125	55	3000	30
2	2KOSH 80-250	125	140	3000	75

KsD Series Cross-Over Three-Stage, Axially Split, Double Entry 1st Stage

KsD



Designed for handling condensate in the steam and water circuit systems of the power stations that burn organic fuel, as well as liquids similar to condensate in viscosity, chemical activity and solid content.

Electrically driven, horizontal three-stage, cross-over, axially split volute-casing centrifugal pumps between bearings, with the first-stage double-entry impeller and single-entry radial impellers in back-to-back arrangement. The pump rotor is carried by the anti-friction bearings. Shaft sealing: soft packed glands or mechanical seals.

Nos	Pump make	Capacity, m ³ /h	Head, m	Rotational speed (synchr.), rpm	Motor nominal power, kW
1	KsD 140-140	140	140	1500	110
2	KsD 125-140	125	140	1500	110
3	KsD 125-125	125	125	1500	90
4	KsD 230-115-2	230	115	1000	160
5	KsD 230-115 -2	210	95	1000	160

Coverage Charts of the Condensate Extraction & Heater Drain Pumps Ks, KsV, KO, KOSH and KsD

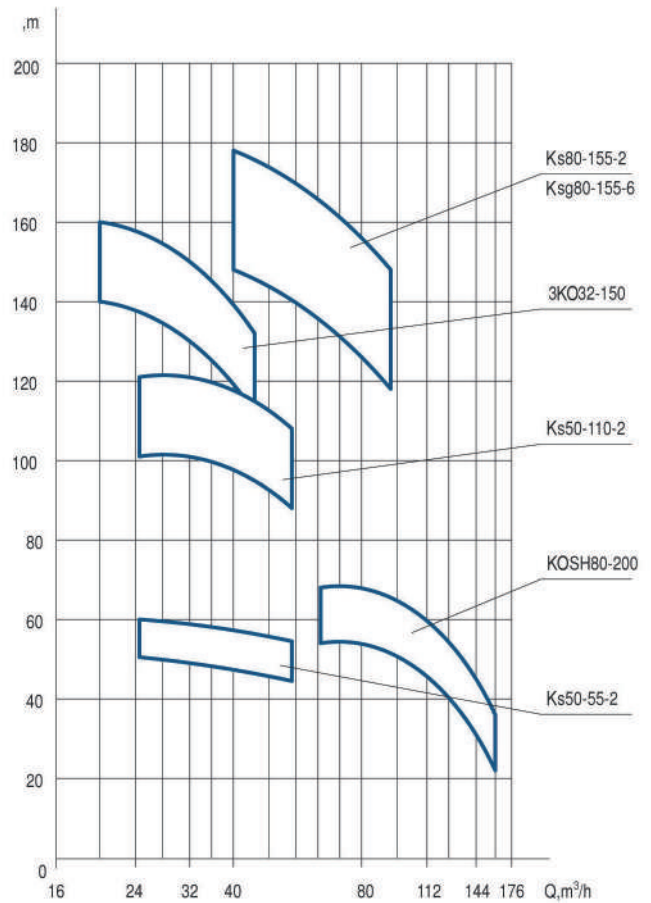
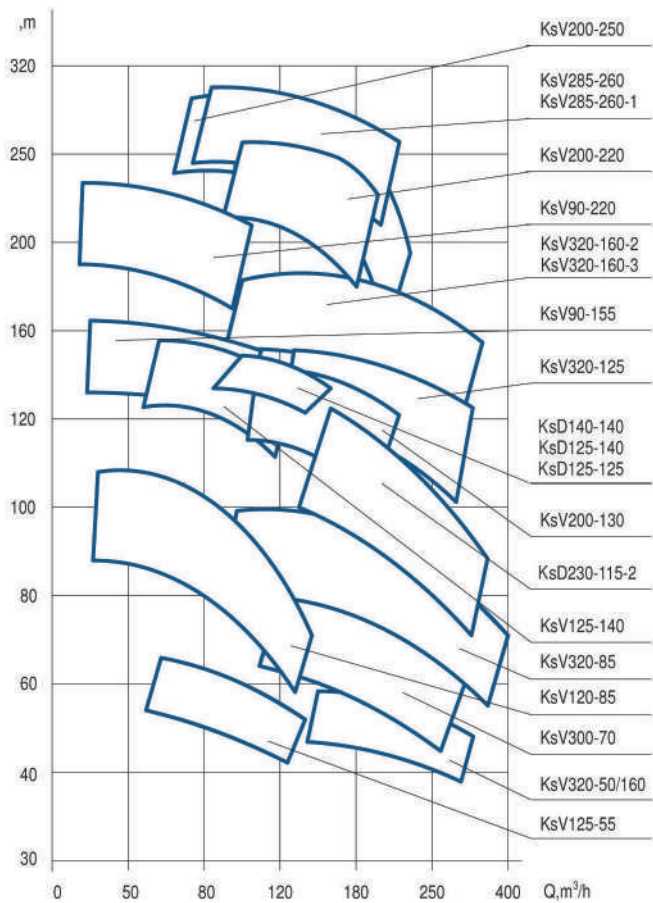
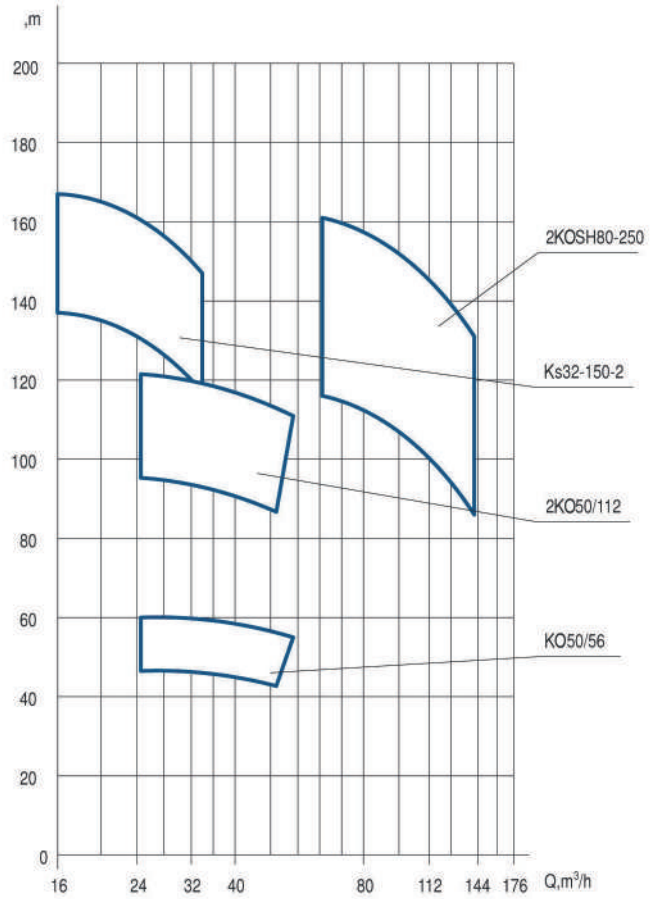
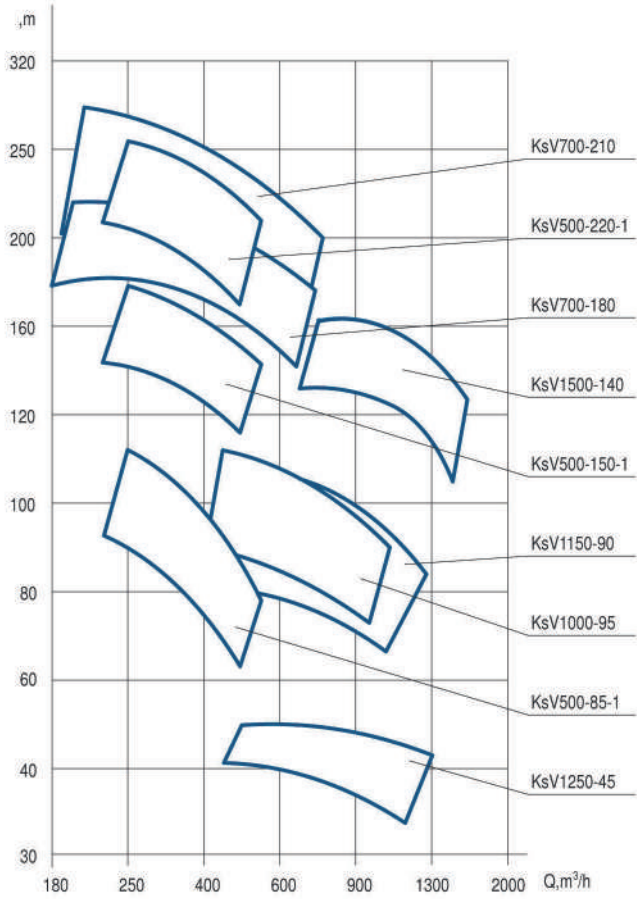

CN Series End Suction, with Overhung Impeller



CN

Nos	Pump make	Capacity, m ³ /h	Head, m	Rotational speed (synchr.), rpm	Motor nominal power, kW
1	CN 100-9	100	9	600	6
2	CN 100-15	100	15	1500	7.5
3	CN 150-7	150	7	1500	6
4	CN 120-15	120	15	1500	11
5	CN 120-35	120	35	3000	30
6	CN 180-55	180	55	3000	55
7	CN 200-40	200	40	3000	37

The pumps CN 120, CN 150, CN 180 and CN 200 are designed for circulating boiler water at temperatures of up to 250°C (up to 315°C in case CN 200-40 make) through the steam-generating circuit of a waste-heat boiler.

The CN 100-9 pump make is designed for circulating slurry having pH ranging from 9.5 to 11.0 at the temperature of 5 to 95°C in the VT type clarifier.

CN 150-7, CN 100-15, CN 120-15 and CN 200-40: Electrically driven, side-suction, barrel-insert inducer single stage centrifugal pumps between bearings. The rotor is carried by oil-ring lubricated ball bearings. Shaft sealing: mechanical seal. Casing mounting: either on the baseplate, or suspended with attachment at the nozzles, the driving torque being transmitted by means of a universal joint.

CN 120-35, CN 180-55 and CN 100-15: Electrically driven, horizontal foot-mounted single-stage end suction volute-casing centrifugal pumps with overhung impeller and bearing bracket. Discharge nozzle radially to the top. The pump rotor is carried by grease-lubricated antifriction bearings. Shaft sealing: by a mechanical seal.

CN 100-9 features a back pull-out design (which allows removal of the rotor assembly without separating the pump casing from the pipeline), an open impeller, a balanced soft-packed gland, oil- or grease-lubricated antifriction bearings. Axial thrust balancing by dynamic action of back blades. Steam inlet connection is provided for flushing the pump after its stopping.

Coverage Chart of the CN Series Circulating Pumps

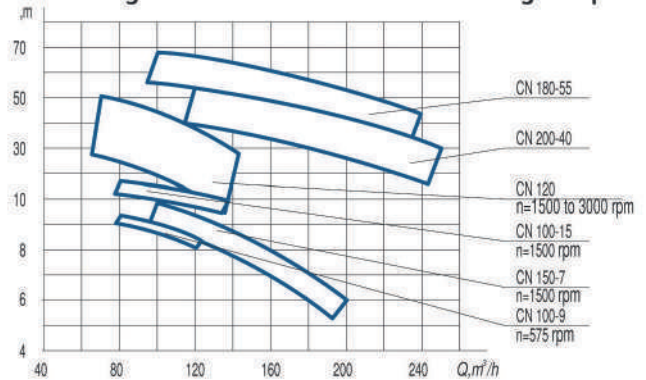

Pumps for Turbine Controlling Systems

Designed to deliver turbine oil into the oil supply and control systems for turbine plants. They can be also used in stationary installations for handling various lube oils similar to turbine oil in their physical and chemical properties.

MV Model Pump: a motor driven, vertically suspended, cantilever, diffuser three-stage ring-section wet sump (submerged) centrifugal pump with a separate discharge. Single entry radial impeller arrangement, with all the impellers facing the same way. The pump rotor is carried by the lower plain bearing and upper antifriction bearing. Shaft sealing: slit seal. The cover plate of an oil inlet sump serves as support plate for the pump.

Nos	Pump make	Capacity, m ³ /h	Head, m	Rotational speed (synchr.), rpm	Motor nominal power, kW
1	MKG 35-100	35	100	3000	18.5
2	MKG 35-100à	35	85	3000	18.5
3	MKG 35-100D	35	112	3000	22
4	MV 60-220	60	220	3000	75
5	MKV 200-36	200	36	1500	45
6	MKV 200-36	190	29	1500	30
7	MKV 200-36	180	25	1500	30
8	MKV 200-36	120	23	1500	16
9	CNSg 60-165	60	165	3000	55

MKG Series Pumps: motor driven, foot mounted, horizontal, end-suction two-stage volute-casing centrifugal pumps with overhung impellers and bearing bracket. Shaft sealing: mechanical seal. The pump rotor is carried by the grease lubricated antifriction bearings.

MKV Series Pumps: motor driven, vertically suspended, cantilever single-stage volute-casing wet sump centrifugal pump with a separate discharge and a single entry radial impeller. The pump rotor is carried by the lower plain bearing and upper anti-friction bearing. Shaft sealing: slit seal. The cover plate of an oil inlet sump serves as support plate for the pump.

CNSg 60-165: for design description, refer to page 8

Coverage Chart of the Pumps for Turbine Controlling Systems MV, MKG, MKV & CNSg

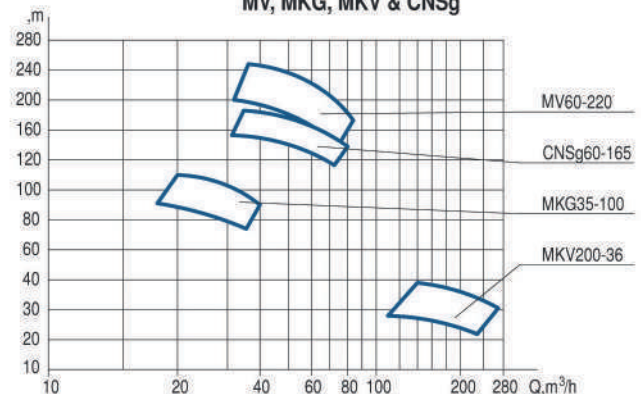



PTA 3750



PTA 3800



PEA 1840



PEA 250



Ksv

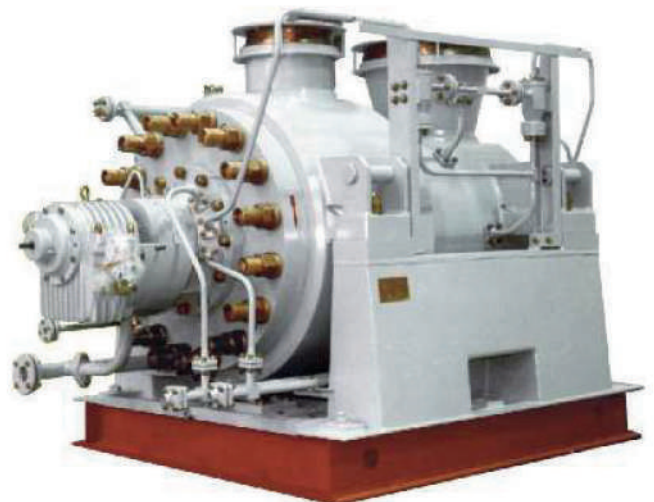

CNS

Pumps For NPS Service

Product name & construction features	Pump make	Equipment applications	Technical data			Safety class	Seismic stability category	Climatic version, location category
			Capacity, m ³ /h	Head, m	Type of drive & its parameters			
Boiler Feed Pumps: horizontal, centrifugal, with plain bearings and shaft sealing by means of mechanical seals (in case of PEA 250-80-3 : horizontal, ring-section, centrifugal, with oil-bath lubricated plain bearings and shaft sealing by means of single mechanical seals; axial thrust compensation by balance disc; flanged nozzles)	PEA 250-80-2	Used as an auxiliary start and shut-down pumps for delivering feedwater from the deaerator to the steam generator during heating-up and cool-down conditions of the primary circuit of NPS power units equipped with VVER-91 pressurized water reactors	250	880	Electric motor: $n = 3000$ rpm; $P_{nom} = 800$ kW; $U = 6000$ V	3	II	M3
	PEA 250-80-3	Used for delivering feedwater to the steam generator at the NPS-2006 project equipped with the VVER-1200 pressurized water reactor	250	880	Electric motor: $n = 3000$ rpm; $P_{nom} = 800$ kW; $U = 10,000$ V	3	II	4
	PEA 1840-80	Designed as a boiler feed pump to deliver feed water from the deaerator to the steam generator at the NPS-2006 project equipped with the VVER-1200 pressurized water reactor. May be used for VVER-TOI design	1840	910	Electric motor: $n = 3000$ rpm; $P_{nom} = 6300$ kW; $U = 10,000$ V	3	II	4
	PTA 3750-75-2	Designed as a boiler feed pump to deliver de-aerated water from gas-extractors (degasers) to steam generators in NPS power units equipped with a VVER-1000 PWR and turbine K-1000-60/3000-2	3400	635	Turbine: $n = 3114$ rpm; $P_{nom} = 6285$ kW	3	II6	B3
	PTA 3750-75-3	Designed as a boiler feed pump to deliver de-aerated water from gas-extractors (degasers) to steam generators in NPS power units equipped with a VVER-1000 PWR and turbine K-12-1,0 -1 or -12 for Rostov NPP and -10-0,5 -1 in case of Kalinin NPP	3750	860	Turbine: $n = 3409$ rpm; $P_{nom} = 9603$ kW	3	II	4
	PTA 3800-20-2	Used as a boiler feed booster pumps to deliver feed water from the de-aerator (gas extractor) to PTA 3750-75-2 and PTA 3750-75-3 BFPs respectively for providing a greater available NPSH to the main pumps for their cavitation-free operation	3450	134	Turbine: $n = 1602$ rpm; $P_{nom} = 1280$ kW	3	II6	B3
	PTA 3800-20-3		3800	160	Turbine: $n = 1753$ rpm; $P_{nom} = 1680$ kW			
Condensate Pumps: vertically suspended multistage diffuser can, with an inner casing of ring section type, shaft sealing by means of a mechanical seal. The pump rotor is carried by the bottom medium lubricated plain bearing and the top thrust and radial antifriction bearing	KsV 125-55-1	Designed for condensate extraction from the condenser of TPN drive turbine to delivery either to the main turbine condenser or to the drainage tank	125	55	Electric motor: $n = 3000$ rpm; $P_{nom} = 37$ kW; $U = 220/300$ V	3	II	4
	KsV 200-220	Used for handling waste steam condensate of the stationary steam turbines of the secondary circuit at the NPP units	200	220	Electric motor: $n = 1480$ rpm; $P_{nom} = 200$ kW; $U = 6000$ V	3	-	4
	KsV 650-135-8	Used for pumping moisture separator drains and heating steam condensate from the moisture separator trap into the turbine condensate line downstream of the LP heater No. 4 to deliver the mixture into the deaerator for the turbo-installations -1200-6,8/50 forming part of 1200 MW PWR power unit at the Belarusian NPP-2006 project	663	141	Electric motor: $n = 1500$ rpm; $P_{nom} = 400$ kW; $U = 10,000$ V	4	II	4
	KsV 360-160-1	Designed as a heater drain pump for pumping heating steam condensate from the heat exchangers of the secondary circuit at the power units of nuclear power stations (NPS) and nuclear heat electropower stations	360	160	Electric motor: $n = 1480$ rpm; $P_{nom} = 250$ kW; $U = 6000$ V	3	-	4
	KsV 360-160-2	Used for drawing water from ECCS (emergency core cooling system) container to boost the inlet pressure of the auxiliary BFPs in case of loss-of-coolant accident at the NPS power units	360	160	Electric motor: $n = 1485$ rpm; $P_{nom} = 250$ kW; $U = 6000$ V	3	I	3
	KsV 360-160-3	Designed as a heater drain pump for pumping heating steam condensate from the LP heater No. 1 back into the main condensate line downstream of the LP heater No. 1 in the turbo-installations -1000-60/1500-2 at the NPS power units equipped with VVER-1000 PWR	360	160	Electric motor: $n = 1480$ rpm; $P_{nom} = 250$ kW; $U = 6000$ V	3	II	4

Product name & construction features	Pump make	Equipment applications	Technical data			Safety class	Seismic stability category	Climatic version, location category
			Capacity, m ³ /h	Head, m	Type of drive & its parameters			
Condensate Pumps: vertically suspended multistage diffuser can, with an inner casing of ring section type, shaft sealing by means of a mechanical seal. The pump rotor is carried by the bottom medium lubricated plain bearing and the top thrust and radial antifriction bearing	KsVA 500-220	Used for handling waste steam condensate of the stationary steam turbines of the secondary circuit at the NPP units	500	220	Electric motor: $n = 1480$ rpm; $P_{nom} = 500$ kW; $U = 6000$ V	3	-	4
	KsVA 630-125-1	Designed as a heater drain pump for pumping heating steam condensate from the heat exchangers of the secondary circuit at the NPP units	630	125	Electric motor: $n = 1480$ rpm; $P_{nom} = 315$ kW; $U = 6000$ V	3	-	4
	KsVA 630-125-2	Designed as a heater drain pump for pumping heating steam condensate from the LP heater No. 3 back into the main condensate line downstream of the LP heater No. 3 in the turbo-installations -1000-60/1500-2 at the NPS power units equipped with VVER-1000 PWR	630	125	Electric motor: $n = 1480$ rpm; $P_{nom} = 315$ kW; $U = 6000$ V	3	II	4
Condensate Pumps: vertically suspended multistage diffuser can, with an inner casing of ring section type, shaft sealing by means of a mechanical seal. The pump rotor is carried by the bottom medium lubricated plain bearing and the top oil-bath lubricated thrust and radial plain bearing	KsVA 650-135	Used for pumping waste steam condensate of the stationary steam turbines and heating steam condensate from the heat exchangers at the power units of nuclear power stations (NPS) and nuclear heat electropower stations	582 to 663	135 to 146	Electric motor: $n = 1480$ rpm; $P_{nom} = 250$ kW; $U = 6000$ V	-	-	4
Pumps for Support Auxiliary Systems: horizontal, foot-mounted, between-bearings, single-stage, axially split volute casing centrifugal, with a double entry radial impeller, antifriction bearings and shaft sealing by means of mechanical seals	CNA 1400-12	Used to boost cooling water pressure at the inlet of the generator gas coolers	1400	12	Electric motor: $n = 750$ rpm; $P_{nom} = 75$ kW; $U = 380$ V	4	II6	4
	CNA 1700-35	Designed for handling demineralized water in the intermediate loop	1700	35	Electric motor: $n = 1500$ rpm; $P_{nom} = 250$ kW; $U = 6000$ V	2	I	M4
	CNA 2000-40	Designed for handling demineralized water in the intermediate loop	2000	40	Electric motor: $n = 1500$ rpm; $P_{nom} = 330$ kW; $U = 6000$ V	2	I	M4
	CNA 4000-95/8	Used as a component cooling water pump for circulation of clean water through essential components to provide the requirements of critical using equipment / services in cooling water under all the operating conditions of the power unit, including emergency situation	3600	55	Electric motor: $n = 750$ rpm; $P_{nom} = 630$ kW; $U = 6000$ V	2	I	4
	CNA 1400-12					3		

Pumps For NPS Service

Product name & construction features	Pump make	Equipment applications	Technical data			Safety class	Seismic stability category	Climatic version, location category
			Capacity, m ³ /h	Head, m	Type of drive & its parameters			
High Pressure Emergency Core Cooling System (ECCS) pumps: horizontal centreline mounted, multistage, barrel-casing centrifugal, with a withdrawable cartridge of ring-section type, plain bearings and shaft sealing by means of mechanical seals	CNA 150-60	Used as a charging pump for injection of boric acid (B_2O_3) solution into the reactor coolant system (primary circuit) during a failure at the NPS units equipped with VVER-91 pressurized water reactor	150	650	Electric motor: $n = 2973 \text{ rpm};$ $P_{\text{nom}} = 630 \text{ kW};$ $U = 6000 \text{ V}$	2	I	4
	CN 150-60-1	Designed for injection of boric acid solution into the reactor coolant system: - to replenish liquid losses in the primary circuit (as a volume control pump) and to remove the fission product decay heat from the reactor core following a loss-of-coolant accident (as a result of rupture of small pipes of up to 100 mm inclusive in diameter) as a charging pump; - to make up the reactor coolant circuit in the emergency situation associated with a loss-of-coolant accident (leakage through rupture of pipes of more than 100 mm in diameter) as a safety injection pump; - to maintain the reactor core in the subcritical condition (as a RHR pump)	153	708	Electric motor: $n = 2973 \text{ rpm};$ $P_{\text{nom}} = 630 \text{ kW};$ $U = 6000 \text{ V}$	2	I	4
	CNA 150-60-2	Designed for injection of boric acid solution into the primary circuit during predictable emergency operations, at which the safety injection system is to be automatically actuated	150	650	Electric motor: $n = 2979 \text{ rpm};$ $P_{\text{nom}} = 630 \text{ kW};$ $U = 10,000 \text{ V}$	2	I	4
	CNA 150-60-3	Designed for injection of boric acid solution into the primary circuit during predictable emergency operations, at which the safety injection system is to be automatically actuated	150	650	Electric motor: $n = 3000 \text{ rpm};$ $P_{\text{nom}} = 630 \text{ kW};$ $U = 10,000 \text{ V}$	2	I	4
	CNA 150-60-4	Designed for injection of boric acid solution into the primary circuit during predictable emergency operations, at which the safety injection system is to be automatically actuated	150	650	Electric motor: $n = 3000 \text{ rpm};$ $P_{\text{nom}} = 630 \text{ kW};$ $U = 6000 \text{ V}$	2	I	4
	CNA 150-110-2	Designed for injection of boric acid solution from the emergency storage tank into the primary circuit of the NPS power units equipped with VVER-1000 PWR during cooldown of the reactor coolant system following a failure	150	980	Electric motor: $n = 3000 \text{ rpm};$ $P_{\text{nom}} = 800 \text{ kW};$ $U = 6000 \text{ V}$	2	I	4
Low Pressure Emergency Core Cooling System (ECCS) Pumps: horizontal, centerline-supported, between-bearings, single-stage axially split volute casing centrifugal, with a double entry radial impeller, plain bearings and shaft sealing by means of mechanical seals. Unified with respect to each other and differ only in the impeller diameter	CNR 800-230-1	Used as a residual heat removal (RHR) pump for injection of boric acid solution into the reactor coolant circuit with the purpose of essential cooling service of the fuel core following a scheduled reactor shutdown and emergency cooldown in the event of failure	800	230	Electric motor: $n = 3000 \text{ rpm};$ $P_{\text{nom}} = 800 \text{ kW};$ $U = 6000 \text{ V}$	2	I	4
	CNSA 700-140-1	Used as a sprinkler system supply pump (containment spray pump) taking suction from the emergency boron storage tank to supply boric acid solution for spray nozzles of a sprinkler system to cool the air space of the safety shell (containment) in case of a significant malfunction	700	140	Electric motor: $n = 3000 \text{ rpm};$ $P_{\text{nom}} = 500 \text{ kW};$ $U = 6000 \text{ V}$	2	I	4

Product name & construction features	Pump make	Equipment applications	Technical data			Safety class	Seismic stability category	Climatic version, location category			
			Capacity, m ³ /h	Head, m	Type of drive & its parameters						
Residual Heat Removal Pumps: horizontal centreline mounted, inducer multistage, barrel-casing centrifugal, with a withdrawable cartridge of ring-section type, plain bearings and shaft sealing by means of mechanical seals	CNSA 750-140	Designed for injection of boric acid solution into the reactor coolant circuit during predictable emergency operations, at which the safety injection system is to be automatically actuated, and to cool down the fuel core following a scheduled reactor shutdown	750	140	Electric motor: $n = 1500 \text{ rpm};$ $P_{\text{nom}} = 500 \text{ kW};$ $U = 6000 \text{ V}$	2	1	4			
	CNSA 750-140-1							4			
	CNSA 750-140-2							4			
	CNSA 750-140a	Designed for injection of boric acid solution into the reactor coolant circuit during predictable emergency operations, at which the safety injection system is to be automatically actuated, and to cool down the fuel core following a scheduled reactor shutdown	800	150	Electric motor: $n = 1500 \text{ rpm};$ $P_{\text{nom}} = 630 \text{ kW};$ $U = 6000 \text{ V}$	2	1	4			
	CNSA 750-140a-1							4			
	CNSA 750-140a-2							Electric motor: $n = 1500 \text{ rpm};$ $P_{\text{nom}} = 630 \text{ kW};$ $U = 10,000 \text{ V}$	2	1	4
	CNSA 750-140a-3										
	CNSA 750-140a-4										

Coverage Charts of the Pumps for NPS Service

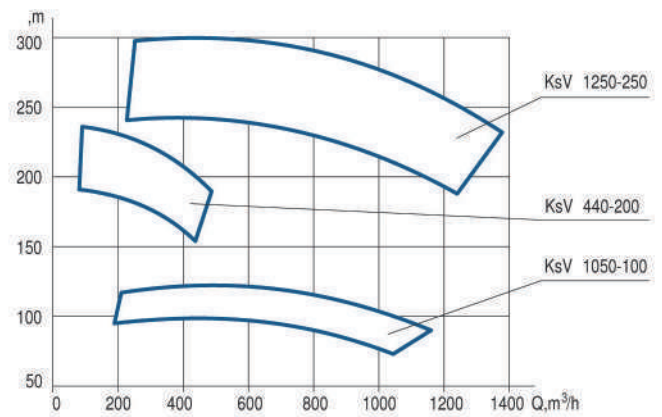
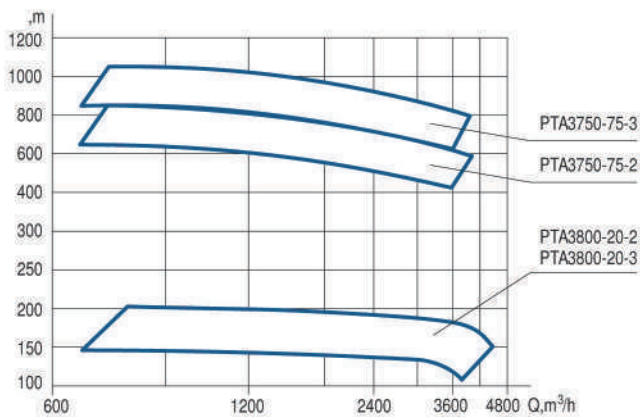
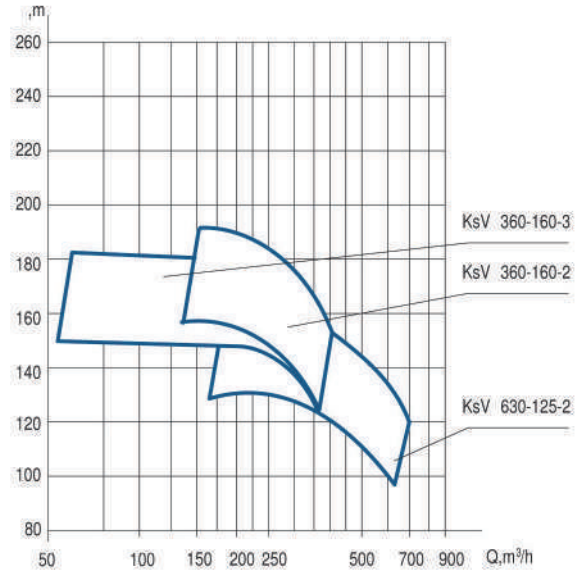
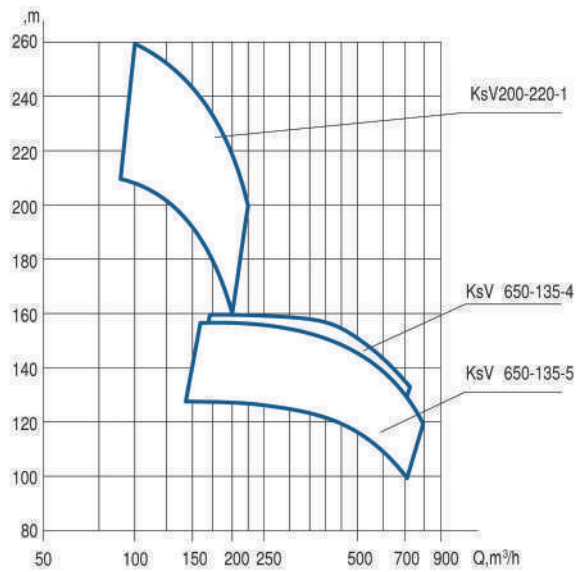

Coverage Charts of the Pumps for NPS Service

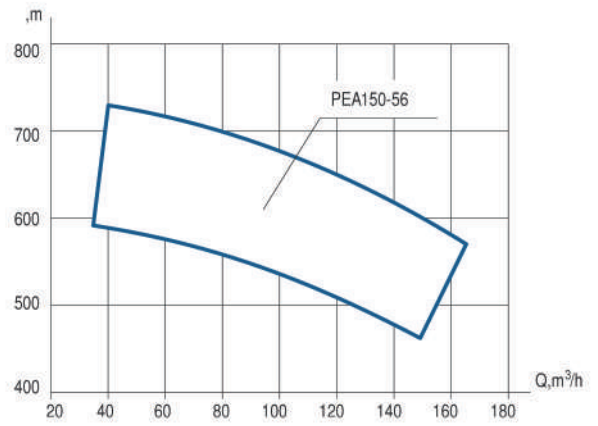
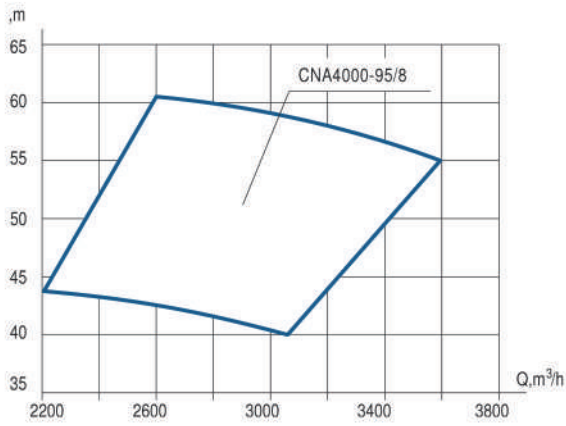
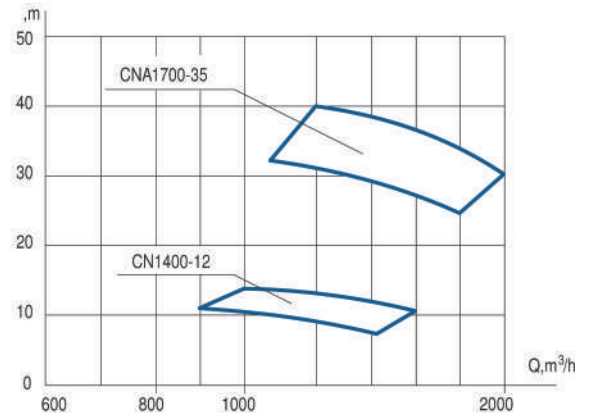
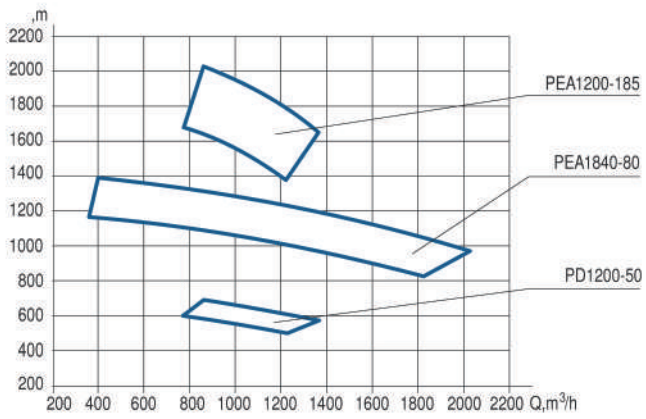
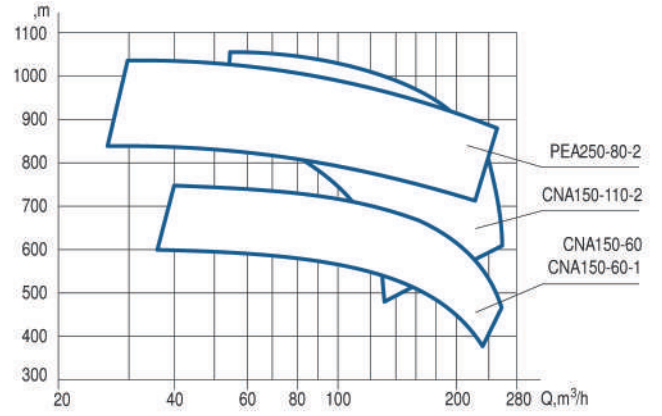
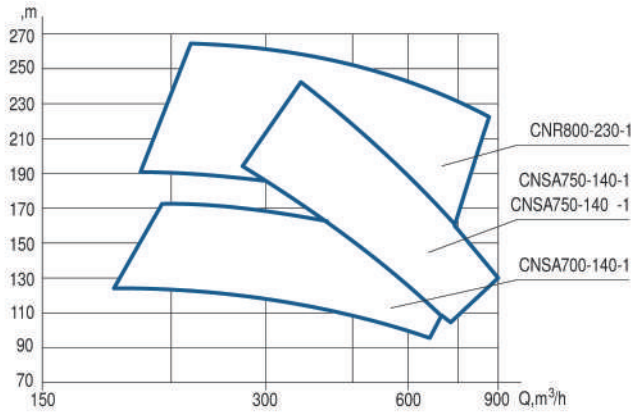

PEA 1840-80

CN & 14M-8x4-1 Series Two-Stage / Multistage Single-Entry Axially Split

Nos	Pump make	Capacity, m ³ /h	Head, m	Rotational speed (synchr.), rpm	Motor nominal power, kW
1	CN 400-105	400	105	1500	200
2	CN 400-105	380	96	1500	160(200)
3	CN 400-105	360	83	1500	132(200)
4	CN 400-210	400	210	1500	400
5	CN 400-210	380	192	1500	315
6	CN 400-210	360	166	1500	250
7	CN 1000-180-3	1000	180	1500	630
8	CN 1000-180a-3	900	157	1500	500
9	14M-8 4-1	600	380	1500	1000

CN: Designed for the water supply to industrial plants and communities. Applied also for agricultural land irrigation and drainage

Horizontal foot-mounted, cross-over, two-stage or four-stage (CN 400-210), axially split volute casing centrifugal pumps between-bearings, with single entry radial impellers mounted back-to-back. Driven by an electric motor or a diesel engine (in case of CN 400-105). The rotor is carried by grease-lubricated antifriction bearings. Shaft sealing: packed glands

14M-8 4-1: Designed for the water supply to industrial plants and communities

Electrically driven, horizontal foot-mounted, cross-over, four-stage, axially split volute casing centrifugal pumps between-bearings, with single entry radial impellers mounted back-to-back. The rotor is carried by grease-lubricated antifriction bearings. Shaft sealing: packed glands

Coverage Charts of the Water-Works Pumps CN and 14M-8x4-1

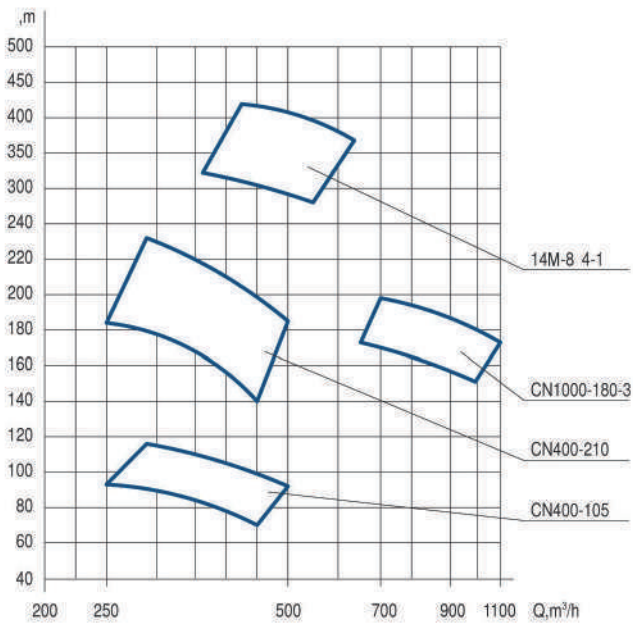

14M-8 4-1



CN

Nos	Pump make	Capacity, m ³ /h	Head, m	Rotational speed (sinchr.), rpm	Motor nominal power, kW
1	CN 3000-197-2	3000	197	1000	2500

Coverage Chart for the CN 3000-197-2 Series Pumps

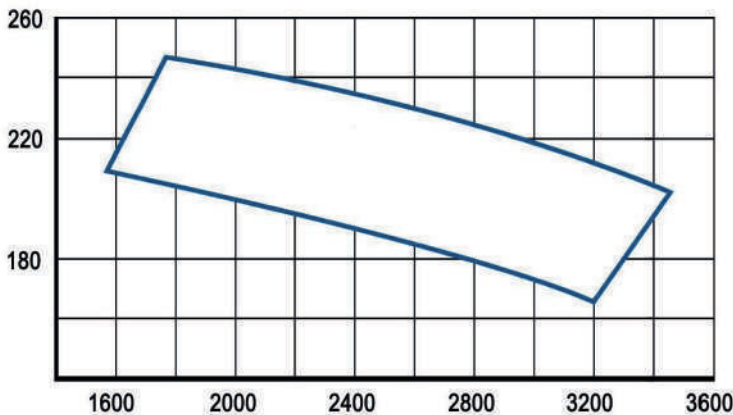

CN 3000-197-2

K & KSH Series End Suction, with Overhung Impeller

Nos	Pump make	Capacity, m ³ /h	Head, m	Rotational speed (synchr.), rpm	Motor nominal power, kW
1	K125-315	200	32	1500	30
2	K125-315	200	26	1500	30
3	K125-315	200	21	1500	22
4	K125-315D	200	35.5	1500	37
5	KSH 100-250	200	80	3000	75
6	KSH 100-250	200	71	3000	75
7	KSH 100-250	200	56	3000	55
8	KSH 100-250D	200	90	3000	90
9	KSH 100-315	200	125	3000	132
10	KSH 100-315	200	105	3000	110
11	KSH 100-315D	250	125	3000	132
12	KSH 125-200	315	50	3000	75
13	KSH 125-200	315	42	3000	55
14	KSH 125-200	315	31.5	3000	45
15	KSH 125-250	315	80	3000	110
16	KSH 125-250	315	71	3000	90
17	KSH 125-250	315	60	3000	75



KSH

Designed for handling water in water supply systems of industrial projects and public utilities. Used also for agricultural land irrigation and drainage.

Electrically driven horizontal end-suction single-stage volute casing centrifugal pumps with overhung impeller and bearing bracket. KSH series pumps have an optimized-NPSH impeller design with blades extending well into the suction chamber. The rotor is carried by grease-lubricated or oil-ring lubricated (in case of KSH series pumps) antifriction bearings. Shaft sealing: packed gland

Coverage Charts of the Water-Works Pumps K and KSH

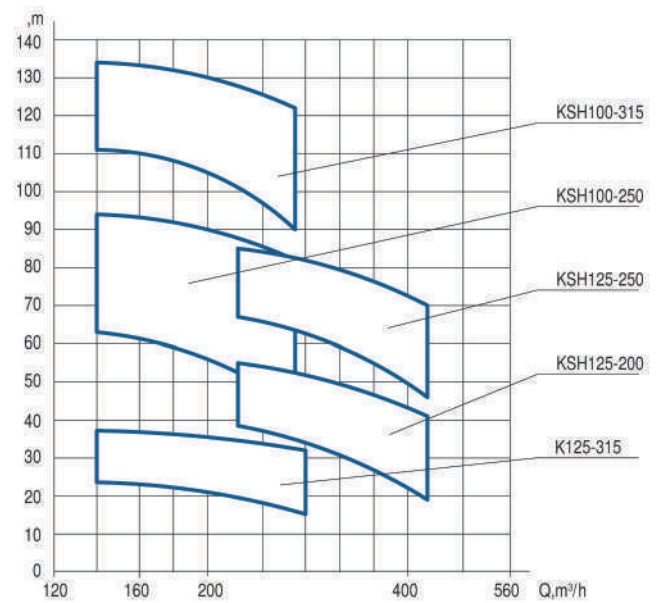

D Series Double Flow Axially Split



Designed for agricultural land irrigation and drainage as well as for handling water in water supply systems of industrial projects and public utilities.

Electrically driven, horizontal foot-mounted, between-bearings, single-stage, axially split volute casing centrifugal pumps with a double entry radial impeller. The rotor is carried by grease-lubricated or oil-ring lubricated (in case of D 6300-80-2 model pump) antifriction bearings. Shaft sealing: packed glands



D12500

Coverage Chart of the Land Irrigation and Drainage Pumps D

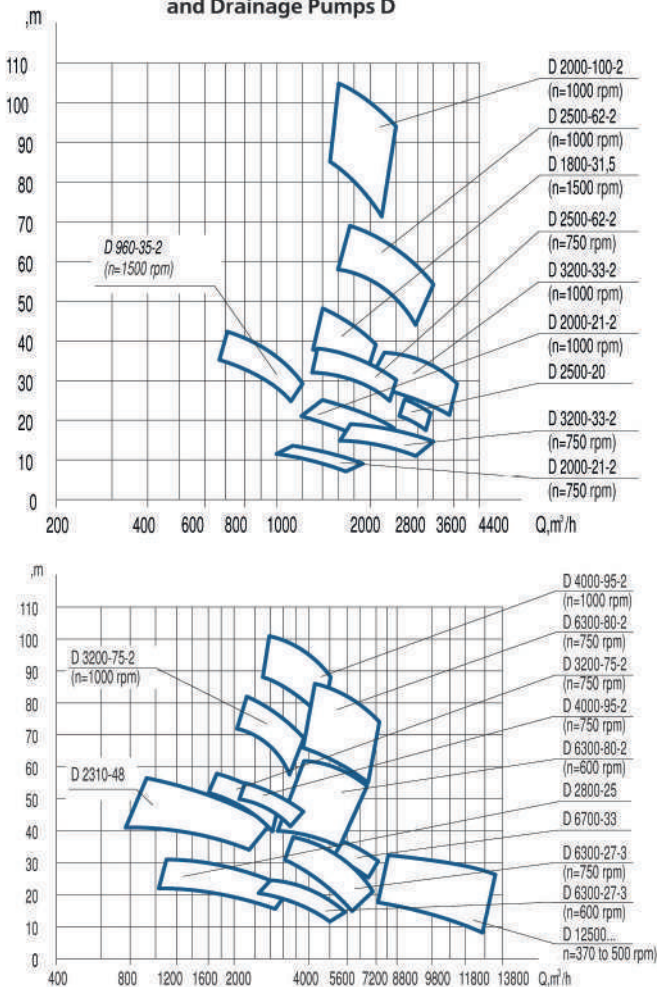

Nos	Pump make	Capacity, m³/h	Head, m	Rotational speed (synchr.), rpm	Motor nominal power, kW
1	D 960-35	960	36	1500	132
2	D 1800-31,5	1800	31.5	1500	315
3	D 2000-21-2	2000	21	1000	160
4	D 2000-21-2	1600	11	800	75
5	D 2000-21a-2	1850	19	1000	132
6	D 2000-21a-2	1500	10	800	55
7	D 2000-216-2	1700	17	1000	110
8	D 2000-216-2	1400	9	800	55
9	D 2000-100-2	2000	100	1000	800
10	D 2000-100a-2	1900	88	1000	630
11	D 2000-1006-2	1800	80	1000	630
12	D 2310-48T3*	2310	48	100	500
13	D 2500-62-2	2500	62	1000	630
14	D 2500-62-2	2000	34	800	250
15	D 2500-62a-2	2300	52	1000	500
16	D 2500-62a-2	1900	29	800	250
17	D 2800-25T3*	2800	25	1000	315
18	D 3200-33-2	3200	33	1000	400
19	D 3200-33-2	2500	17	800	160
20	D 3200-33a-2	3000	29	1000	315
21	D 3200-33a-2	2400	15	800	132
22	D 3200-336-2	2800	25	1000	315
23	D 3200-336-2	2300	13	800	110
24	D 3200-75-2	3200	75	1000	1000
25	D 3200-75-2	2500	42	800	400
26	D 3200-75a-2	3000	65	1000	800
27	D 3200-75a-2	2300	35	800	400
28	D 4000-95-2	4000	95	1000	1600
29	D 4000-95-2	3200	50	800	630
30	D 4000-95a-2	3700	82	1000	1250
31	D 4000-95a-2	3000	45	800	630
32	D 6300-27-3	6300	27	800	630
33	D 6300-27-3	5000	17	600	315
34	D 6300-27-3-1	5000	32	800	630
35	D 6300-27-3-1	4000	20	600	315
36	D 6300-27a-3	5800	24	800	500
37	D 6300-27a-3	4620	15	600	250
38	D 6300-276-3	5450	22	800	400
39	D 6300-276-3	4350	14	600	200
40	D 6300-80-2	6300	80	800	2000
41	D 6300-80-2	5000	50	600	1000
42	D 6300-80a-2	5900	70	800	1600
43	D 6300-80a-2	4700	45	600	800
44	D 6300-806-2	5500	60	800	1250
45	D 6300-806-2	4400	38	600	630
46	D 6700-33	6700	33	800	800
47	D 12500-10	12500	10	400	500
48	D 12500-24	9300	32	500	1250
49	D 12500-24	12500	24	500	1250

* – Tropicalized version

Series D (DESUM)

Electrically driven, foot-mounted, between-bearings, inline, single-stage, double-suction, axially split volute casing, heavy-duty industrial pumps with a basically horizontal shaft. Available with optional vertical mounting (DV configurations). Accurate positioning of the upper-to-lower casing halves with pins for ease of assembly.

The rotor is carried by grease-lubricated or oil-bath lubricated antifriction bearings. Cooling system can also be provided. Shaft sealing: packed glands or API 682 single / double mechanical seals.

The pump is designed to be capable of remaining functional in the areas of seismic hazard of magnitude up to 9 (MSK-64 scale).

Nozzle flanges are made according to DIN / ANSI / ISO. The pump shaft is completely protected against handled medium.

Impeller material options: cast iron, steel, bronze.

The pump casing is basically made of high-strength cast iron.

Nos	Pump make	Capacity, m ³ /h	Head, m	Rotational speed (sinchr.) , rpm
1	D(DV) 350-580	2 850	105	1 500
		2 500	110	1 500
2	D(DV) 350-725d	2 900	180	1 500
		2 500	180	1 500
3	D(DV) 400-660	4 300	140	1 500
		2 850	60	1 000
		2 150	36	750
4	D(DV) 400-990	3 200	130	1 000
		2 700	100	1 000
5	D(DV) 500-735	4 400	75	1 000
		3 600	70	1 000
6	D(DV) 500-875	5 000	110	1 000
7	D(DV) 500-875A	6 000	105	1 000
		5 000	100	1 000
8	D(DV) 500-875B	4 000	110	1 000
		4 000	160	1 000
9	D(DV) 500-1050	3 500	140	1 000
		5 900	70	1 000
10	D(DV) 600-720	4 500	40	750
		3 500	40	750
		4 000	40	750
		9 700	120	1 000
11	D(DV) 700-1000A	8 500	115	1 000
		5 000	40	600
12	D(DV) 700-1000B	8 000	72	750
		7 400	72	750
13	D(DV) 700-700	8 500	27	750
		7 250	27	750

Coverage Chart of the New Generation Land Irrigation and Drainage Pumps

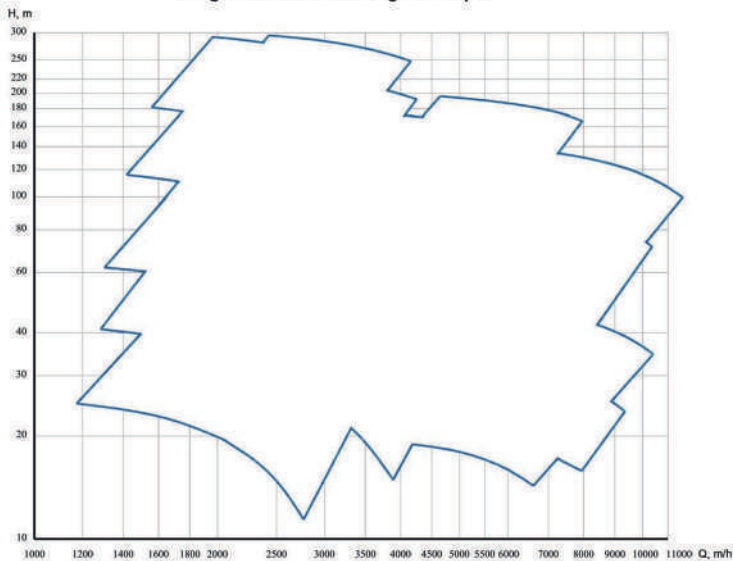

D 700-1000A



D 600-720



D 700-700

NOU Series Vertical Sump Diffuser



Designed for pumping out crude oil and oil products that leak out of pipeline pumps and for their injection into the suction pipeline of an oil pumping station.

Electrically driven, vertically suspended, wet-pit end-suction diffuser multistage segmental centrifugal pumps in cantilever design, with single flow radial impellers, a separate discharge pipe, a motor stool and a can (outer casing). The inner casing (a withdrawable rotating assembly) of ring-section design may be installed in an existing vessel or a sump* to be submerged in the medium pumped. The rotor is carried by medium-lubricated radial plain bearing at the balance drum and intermediate bearing and a grease-lubricated top thrust and radial antifriction bearing (of two ball bearings). No shaft sealing is required.

NOTE: *Overall and mounting dimensions of the withdrawable element mounting plate (pump cover plate) are made specific after the Customer's submittal of data on fitting dimensions of a tank mouth flange.

Made in compliance with Transneft's General and Specific Engineering Requirements (OTT and STT resp.).

Nos	Pump make	Capacity, m ³ /h	Head, m	Rotational speed (synchr.), rpm	Motor nominal power, kW
1	NOU 12.5-80	0.0035 (12.5)	80	3000	To be determined by the manufacturer according to kinematic viscosity of handled medium
2	NOU 12.5-120		120		
3	NOU 12.5-160		160		
4	NOU 12.5-200		200		
5	NOU 12.5-240		240		
6	NOU 12.5-280		280		
7	NOU 12.5-320		320		
8	NOU 12.5-360		360		
9	NOU 12.5-400		400		
10	NOU 12.5-440		440		
11	NOU 12.5-480		480		
12	NOU 12.5-520		520		
13	NOU 12.5-560		560		
14	NOU 12.5-600		600		
15	NOU 12.5-640		640		
16	NOU 12.5-680		680		
17	NOU 12.5-720		720		
18	NOU 12.5-760		760		
19	NOU 12.5-800		800		
20	NOU 25-60	0.007 (25)	60	3000	To be determined by the manufacturer acc. to kinematic viscosity of handled medium
21	NOU 25-90		90		
22	NOU 25-120		120		
23	NOU 25-150		150		
24	NOU 25-180		180		
25	NOU 25-210		210		
26	NOU 25-240		240		
27	NOU 25-270		270		
28	NOU 25-300		300		

29	NOU 25-330	0.007 (25)	330	3000	To be determined by the manufacturer acc. to kinematic viscosity of handled medium
30	NOU 25-360		360		
31	NOU 25-390		390		
32	NOU 25-420		420		
33	NOU 25-450		450		
34	NOU 25-480		480		
35	NOU 25-510		510		
36	NOU 25-540		540		
37	NOU 25-570		570		
38	NOU 25-600		600		
39	NOU 40-120	0.011 (40)	120	3000	To be determined by the manufacturer acc. to kinematic viscosity of handled medium
40	NOU 40-180		180		
41	NOU 40-240		240		
42	NOU 40-300		300		
43	NOU 40-380		380		
44	NOU 40-420		420		
45	NOU 40-460		460		
46	NOU 40-540		540		
47	NOU 40-600		600		
48	NOU 40-660		660		
49	NOU 40-730		730		
50	NOU 40-780		780		
51	NOU 40-840		840		
52	NOU 40-900		900		
53	NOU 50-350		0.014 (50)		



Coverage Chart of the Oil Leakage Drain Pumps NOU

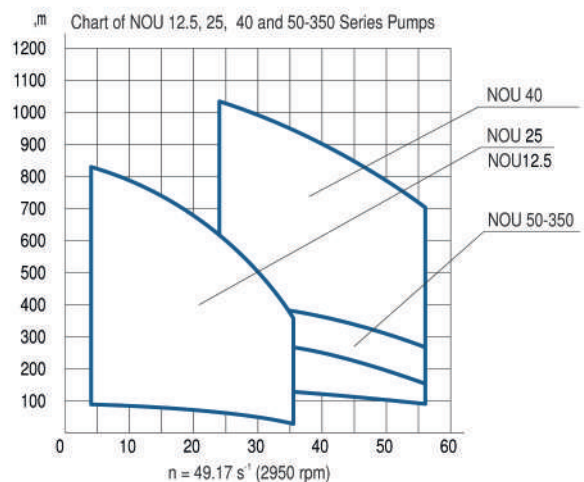

**NGPN-M Series
Inducer Double Flow Axially Split**

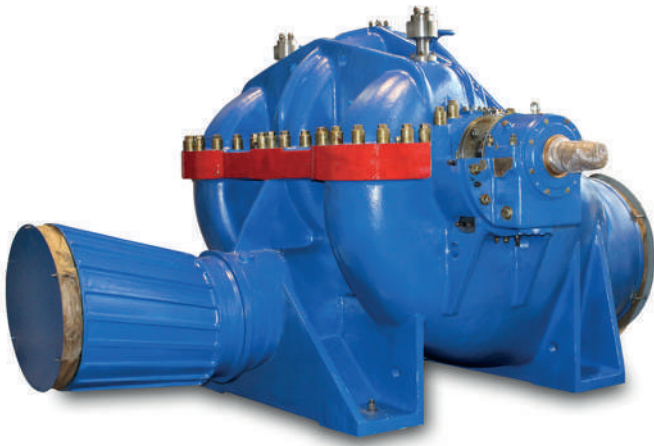

NGPN-M 3600-78



NGPN-M 1250-160

NGPN-M



Designed to ensure the necessary suction head (a greater NPSH available) for the main pipeline pumps. May be used also for pumping crude oil in other process systems at the pump stations or at other industrial projects.

Electrically driven, horizontal foot-mounted, between-bearings, single-stage, axially split volute casing centrifugal pumps with a double entry radial impeller and an inducer on each side to reduce the NPSH value. Rotor radial forces are taken up by the radial antifriction bearings with self-contained oil-ring lubrication. The residual axial thrust of the rotor is absorbed by two single row angular-contact antifriction bearings mounted back to back.

Shaft sealing: by single mechanical seals, each provided with an auxiliary (safety) seal on the atmosphere side. Cyclone separators are employed to clean handled oil extracted at the top connection from contaminants and solids and to supply cleaned liquid for sealing the mechanical seals.

Made in compliance with Transneft's General and Specific Engineering Requirements (OTT and STT resp.).

Nos	Pump make	Capacity, m ³ /h	Head, m	Rotational speed (synchr.), rpm	Motor nominal power, kW	NPSHR
1	NGPN-M 1250-160	1250	160	1500	1000	1.8
2	NGPN-M 1250/0,5-160	750	160	1500	800	1.9
3	NGPN-M 1250-160	1500	160	1500	1250	2.0
4	NGPN-M 2500-160	2500	160	1500	1800	2.5
5	NGPN-M 2500-160	3000	160	1500	2000	2.7
6	NGPN-M 3600-120	3600	110	1000	1600	2.5
7	NGPN-M 3600-120	3600	120	1000	1600	2.5
8	NGPN-M 3600-120	4000	125	1000	2000	3.0
9	NGPN-M 3600-120	2500	60	1000	1000	2.5
10	NGPN-M 3600-78	3600	78	1000	1000	2.5
11	NGPN-M 3600-78	3600	90	1000	1250	2.5

Coverage Chart of the Booster Pipeline Pumps DN

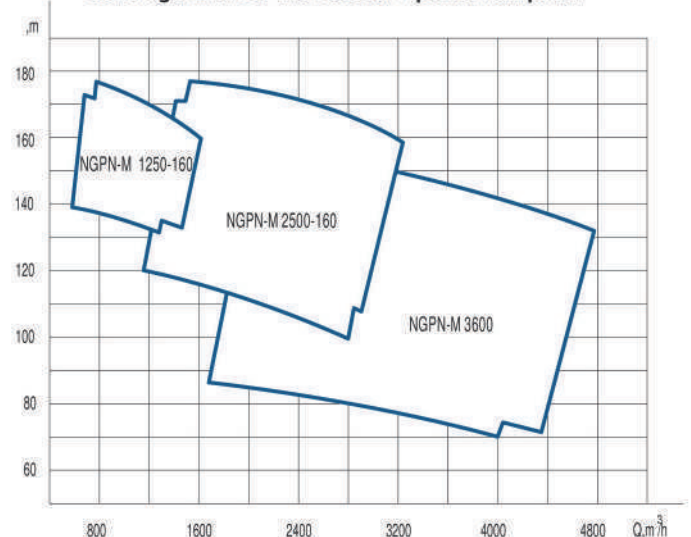

Designed for delivering crude oil or oil products to the main pipeline pumps to ensure their satisfactory suction performance (cavitation-free operation). Suitable also as mixing pumps to transfer oil in tank farms and as loading pumps to fill end products into tank wagons at the oil refineries.

Electrically driven vertically suspended, end-suction single- or multistage (according to the required head) diffuser centrifugal pumps equipped with an inducer. The major pump components are a can (outer casing) and a withdrawable assembly with a motor stool. Upgraded versions (identified with "M") feature a bowl-shaped delivery casing. The pump rotor is carried by the top thrust and radial bearing (comprising two ball bearings) and the bottom medium lubricated plain bearing. Shaft sealing: by mechanical seal

Made in compliance with Transneft's General and Specific Engineering Requirements (OTT and STT resp.).

Nos	Pump make	Capacity, m ³ /h	Head, m	Rotational speed (synchr.), pm	Motor nominal power, kW
1	NPV 150-60	150	60	3000	90
2	NPV 150-60	150	90	3000	90
3	NPV 300-60-	300	40	3000	90
4	NPV 300-60	300	60	3000	90
5	NPV 300-60	300	150	3000	200
6	NPV 600-60	600	60	1500	200
7	NPV 1250-30-M	1250	30	1000	160
8	NPV 1250-60-M	1250	60	1000	315
9	NPV 1250-110-M	1250	110	1000	630
10	NPV 2500-40-M	2500	40	1000	400
11	NPV 2500-80-M	2500	80	1000	800
12	NPV 2500-120-M	2400	103	1000	800
13	NPV 2500-120-M	2500	120	1000	1250
14	NPV 2500-120a-M	2500	110	1000	1000
15	NPV 3600-45-M	3600	45	1000	630
16	NPV 3600-90-M	3600	90	1000	1250
17	NPV 3600-90-M	4500	80	1000	1600
18	NPV 3600-120-M	3600	120	1000	1600
19	NPV 3600-135-M	3600	135	1000	2000
20	NPV 3600-135a-M	3600	120	1000	1600
21	NPV 5000-60-M	5000	60	1000	1250
22	NPV 5000-120-M	5000	120	1000	2000
23	NPV 5000-120-M1	5000	120	1000	2000
24	NPV 5000-120-M2	5000	120	1000	2000



NPV600

Coverage Chart of the Booster Pipeline Pumps NPV

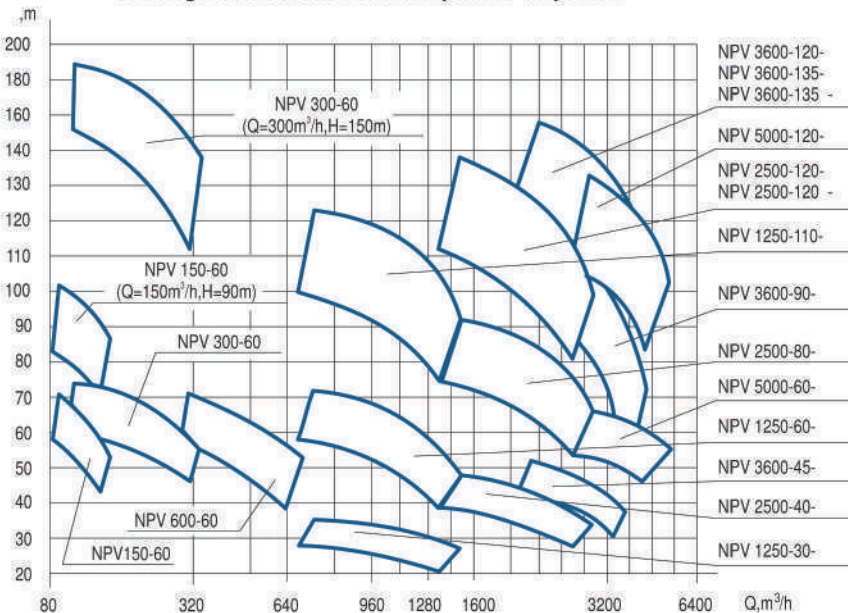

20 NV Series Vertical Line-Shaft, Multistage Wet-Pit

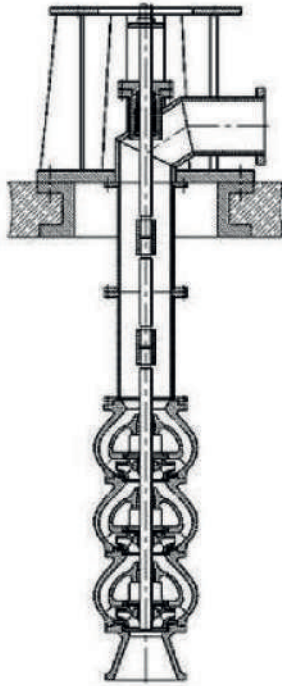

Designed for transferring and pumping crude oil and refined products with temperatures ranging from minus 15°C to +80°C as well as water out of underground storage tanks. USTs of the standard line have various capacity and various burial depth without exceeding 15 m. The pumps can be applied for any such USTs, the required pump submergence (distance from the pump mounting surface to the lowest point of its suction nozzle) being obtained by changing the number of rising main (column pipe) elements.

Vertically suspended, wet-pit submerged multistage ring-section centrifugal pumps with bowl-type vaned casings. Back wear rings balance the axial hydraulic forces. Bottom intake with open line shaft design. Driven by a motor from the ground level with shaft extending below ground to the pump. In case of the pump 24 NV 18x1 its rotor is carried by the oil-lubricated top thrust and radial antifriction bearing and the medium lubricated bottom and intermediate hydrodynamic plain bearings. Shaft sealing: by mechanical seal. Made in compliance with Transneft's General and Specific Engineering Requirements (OTT and STT resp.).

Nos	Pump make	Capacity, m ³ /h	Head, m	Rotational speed (synchr.), pm	Motor nominal power, kW
1	20 NV 22x3	600	65	1500	160
2	20 NV 22x2	600	43	1500	160
3	24 NV 18x1	1200	40	1500	250

NM Series Multistage Segmental/Radially Split Barrel

Designed for transporting crude oil and refined oil products through long-distance pipelines.

Electrically driven, horizontal, between-bearings, multistage diffuser centrifugal pumps of segmental or barrel (in case of NM 500-800 and NM1250-400) type with a withdrawable cartridge of ring-section type. Single flow impeller arrangement, with all the impellers facing the same way. The pump rotor is carried by the plain bearings with forced oil lubrication. Shaft sealing: by mechanical seals.

The pumps can be arranged both in series and in parallel. Made in compliance with Transneft's General and Specific Engineering Requirements (OTT and STT resp.).

Nos	Pump make	Capacity, m ³ /h	Head, m	Rotational speed (synchr.), pm	Motor nominal power, kW
1	N 65-550	65	550	3000	200
2	NM 125-550	125	185	3000	110
3	NM 125-550	125	183.6	3000	200
4	NM 125-550	125	550	3000	315, 400
5	NM 125-550	149	218	3000	200
6	NM 180-500	163.9	256.6	3000	315
7	NM 180-500	180	500	3000	400, 500
8	NM 180-500-M	180	500	3000	400
9	NM 250-475	250	475	3000	500, 630
10	NM 300-500	250	550	3000	630, 800, 1000
11	NM 360-460	360	780	3000	1000
12	NM 360-460	360	460	3000	630, 800
13	NM 360-460	360	405	3000	500
14	NM 500-300	500	300	3000	630, 800
15	NM 500-300	500	260	3000	500
16	NM 500-800	500	800	3000	1600
17	NM 500-800	500	670	3000	1250
18	NM 710-280	710	280	3000	800, 1000
19	NM 1250-400	1250	400	3000	1600

Coverage Chart of the Vertical Submerged Process Pumps 20 NV

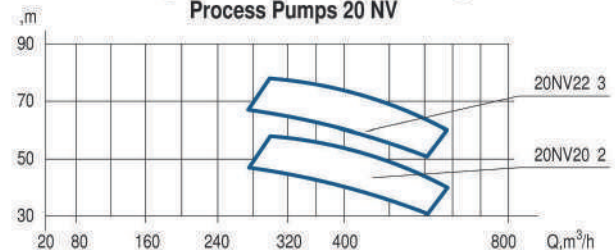

NM

Coverage Chart of the Pipeline Pumps NM

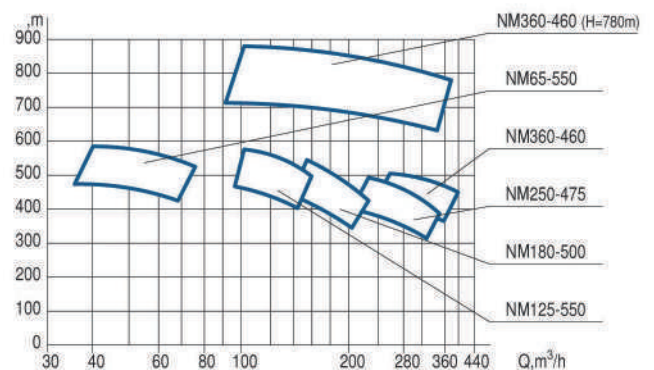

NM Series Double Flow Axially Split

Nos	Pump make	Capacity, m ³ /h	Head, m	Rotational speed (synchr.), pm	Motor nominal power, kW
20	N 1250-260	900	255	3000	800
21	NM 1250-260	1250	260	3000	1250
22	NM 1250-260	1565	M ₂₅₀	3000	1600
23	NM 1700-300	1700	300	3000	1600
24	NM 2500-230	1250	220	3000	1250
25	NM 2500-230	1800	225	3000	1600
26	NM 2500-230	2500	230	3000	2000
27	NM 2500-230	3150	220	3000	2500
28	NM 3600-230	1800	225	3000	1600
29	NM 3600-230	2500	225	3000	2000
30	NM 3600-230	3600	230	3000	2500
31	NM 3600-230	4500	220	3000	3150
32	NM 7000-210	3500	205	3000	2500
33	NM 7000-210	5000	210	3000	3150
34	NM 7000-210	6300	195	3000	5000
35	NM 7000-210	7000	210	3000	5000
36	NM 7000-210	8750	205	3000	6300
37	NM 10000-210	5000	205	3000	4000
38	NM 10000-210	7000	200	3000	5000
39	NM 10000-210	10000	177	3000	5000
40	NM 10000-210	10000	210	3000	6300
41	NM 10000-210	12500	210	3000	8000
42	NM 1250-260-2.1	1250	260	3000	1250
43	NM 1250-260a-2.1	1135	215	3000	1250
44	NM 1250-260b-2.1	1070	192	3000	1250
45	NM 1250/0.7-260-2.1	900	265	3000	1250
46	NM 1250/1.25-260-2.1	1565	270	3000	1600
47	NM 2500-230-2.1	2500	230	3000	2000
48	NM 2500-230a-2.1	2300	195	3000	2000
49	NM 2500-230b-2.1	2190	176	3000	2000
50	NM 2500/0.5-230-2.1	1250	220	3000	1250
51	NM 2500/0.7-230-2.1	1800	225	3000	1600
52	NM 2500/1.25-230-2.1	3150	225	3000	2500
53	NM 3600-230-2.1	3600	230	3000	2500
54	NM 3600-230a-2.1	3325	196	3000	2500
55	NM 3600-230b-2.1	3230	185	3000	2500
56	NM 3600/0.5-230-2.1	1800	230	3000	1600
57	NM 3600/0.7-230-2.1	2500	230	3000	2000
58	NM 3600/1.25-230-2.1	4500	220	3000	3150
59	NM 7000-210-2.1	7000	210	3000	5000
60	NM 7000-210a-2.1	6630	188	3000	5000
61	NM 7000-210b-2.1	6340	172	3000	5000
62	NM 7000/0.5-210-2.1	3500	205	3000	2500
63	NM 7000/0.7-210-2.1	5000	210	3000	4000
64	NM 7000/1.25-210-2.1	8750	210	3000	6300
65	NM 10000-210-2.1	10000	210	3000	6300
66	NM 10000-210a-2.1	9600	194	3000	6300
67	NM 10000-210b-2.1	9300	182	3000	6300
68	NM 10000/0.5-210-2.1	5000	210	3000	4000
69	NM 10000/0.7-210-2.1	7000	210	3000	5000
70	NM 10000/1.25-210-2.1	12500	210	3000	8000
71	NM 10000/1.2-380-2	12000	380	3000	14000

Nos	Pump make	Capacity, m ³ /h	Head, m	Rotational speed (synchr.), pm	Motor nominal power, kW
72	NM 10000-380a-2	9600	380	3000	14000
73	NM 10000/0.5-380-2	4500	350	3000	14000
74	NM 10000/0.7-380ж-2	7003/11654*	207	3000	12000
75	NM 10000/0.7-380e-2	7003/11654*	224	3000	12000
76	NM 10000/0.7-380в-2	7003/11654*	250	3000	12000
77	NM 10000/0.7-380a-2-C	7003/11654*	283	3000	12000
78	NM 10000/0.7-380r-2-C	7003/11654*	233	3000	12000
79	NM 10000-250-3-C	9150	245	3000	8000
80	NM 10000/0.6-250-3-C	5250	251	3000	8000
81	NM 10000/0.5-250a-3-C	5250	223	3000	8000
82	NM 7000/1.1-250-3-C	7500	249	3000	6300
83	NM 7000/0.7-250-3-C	5250	247	3000	6300
84	NM 7000/0.6-250-3-C	4500	247	3000	6300
85	NM 7000/0.5-250a-3.1	3660	202	3000	6300
86	NM 7000/0.4-250a-3.1	2786	238	3000	6300
87	NM 7000/0.85-250-3.2	1800	250	3000	5500
88	NM 7000/0.85-250-3.2	6000	250	3000	5500
89	NM 7000/0.85-250-3.2	3300	250	3000	5500
90	NM 2500/1.25-250-3.2	2900	240	3000	2500
91	NM 2500/1.25-250-3.2	1250	240	3000	2500

* - obtainable with an interchangeable replacement rotor for the maximum capacity to meet the requirements of the full development of pipeline projects

Designed for transporting crude oil through long-distance pipelines.

Electrically driven, horizontal foot-mounted, between-bearings, single-stage, axially split volute casing centrifugal pumps with a double entry radial impeller. The rotor is carried by the pressure oil lubricated plain bearings. The residual rotor axial thrust is absorbed by an angular-contact ball bearing (optional hydrodynamic axial plain bearing). Shaft sealing: basically by single mechanical seals, each provided with an auxiliary (safety) seal (a floating throttle bushing) on the atmosphere side; optional dual mechanical seals with a barrier fluid sealing system.

Made in compliance with Transneft's General and Specific Engineering Requirements (OTT and STT resp.).

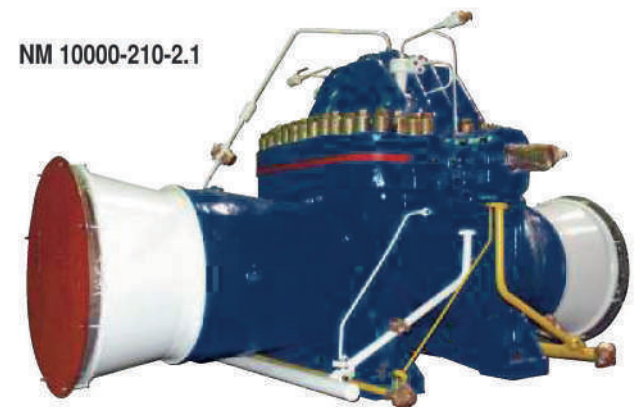

NM 10000-210-2.1

Coverage Chart of the Pipeline Pumps NM

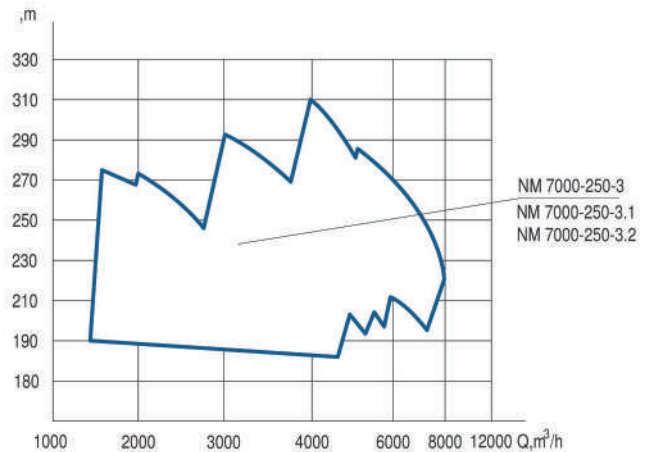
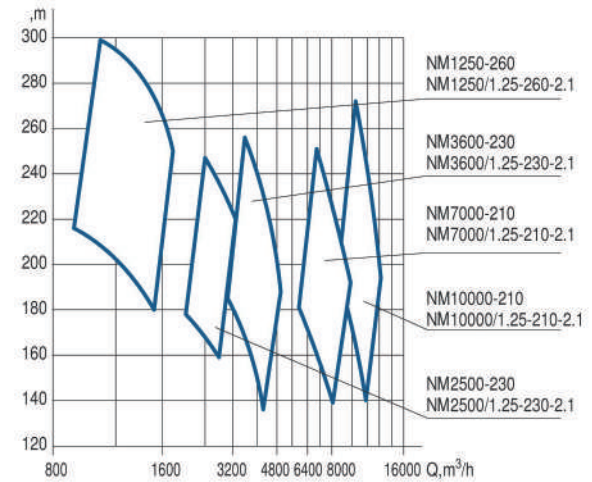
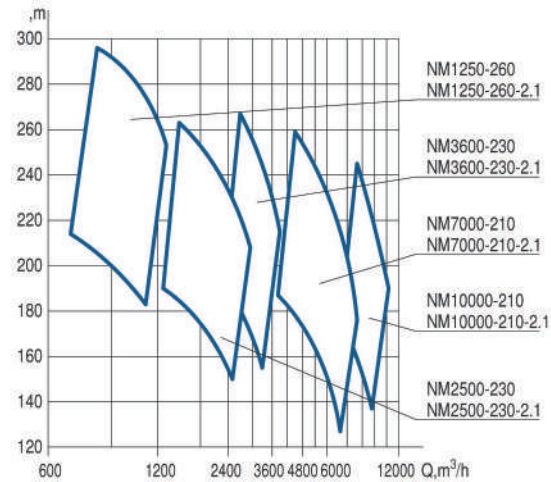
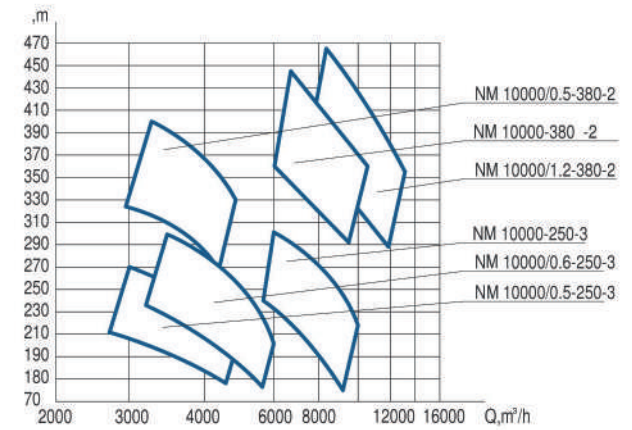
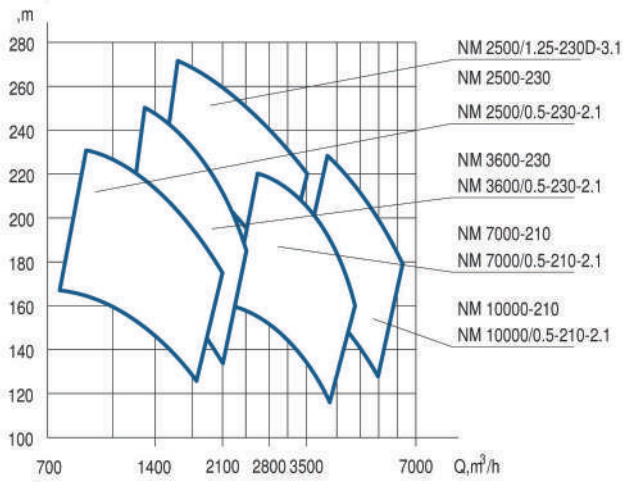
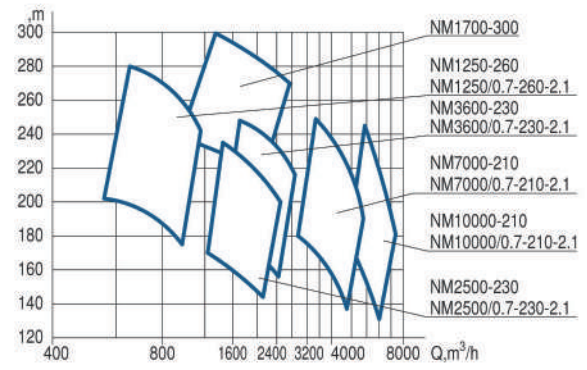
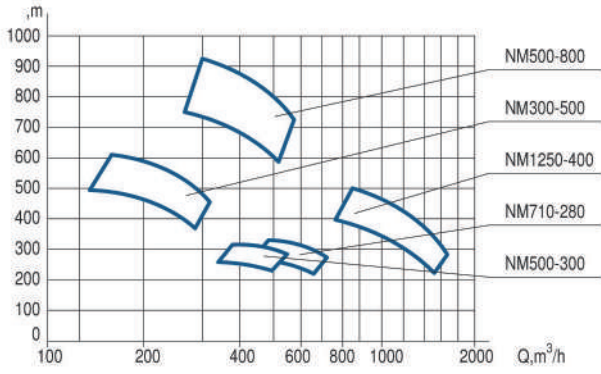

NMV Series In-Line Vertical Multistage Can

Designed for transporting crude oil through long-distance pipelines and oil products (diesel fuel, motor petrol, jet engine fuel) through product pipelines.

Vertically suspended, in-line, can, end-suction multistage diffuser centrifugal pumps with the first stage double flow impeller, provided with inducers. Driven by induction motors by means of a spacer-type diaphragm flexible coupling. The pump rotor is carried by the top thrust and radial antifriction bearing and the bottom medium lubricated hydrodynamic plain bearing. Shaft sealing: by mechanical seal

Designed in compliance with API Standard 610 requirements.

Coverage Chart of the Vertical Process Pumps NMV

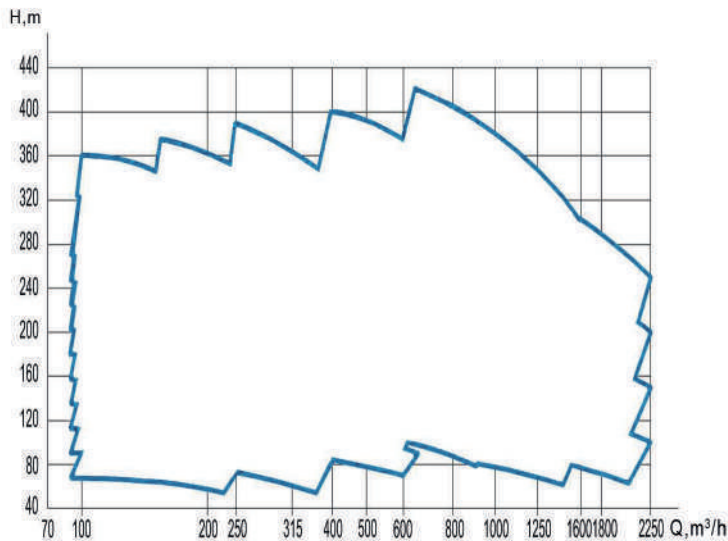

Nos	Pump make	Capacity, m ³ /h	Head, m	Rotational speed (synchr.), rpm
1	NMV 200-75	200	75	1500
2	NMV 200-100	200	100	1500
3	NMV 200-125	200	125	1500
4	NMV 200-150	200	150	1500
5	NMV 200-175	200	175	1500
6	NMV 200-200	200	200	1500
7	NMV 200-225	200	225	1500
8	NMV 200-250	200	250	1500
9	NMV 200-275	200	275	1500
10	NMV 200-300	200	300	1500
11	NMV 315-90	315	90	1500
12	NMV 315-120	315	120	1500
13	NMV 315-150	315	150	1500
14	NMV 315-180	315	180	1500
15	NMV 315-210	315	210	1500
16	NMV 315-240	315	240	1500
17	NMV 315-270	315	270	1500
18	NMV 315-300	315	300	1500
19	NMV 500-105	500	105	1500
20	NMV 500-140	500	140	1500
21	NMV 500-175	500	175	1500
22	NMV 500-210	500	210	1500
23	NMV 500-245	500	245	1500
24	NMV 500-280	500	280	1500
25	NMV 500-315	500	315	1500
26	NMV 800-120	800	120	1500
27	NMV 800-160	800	160	1500
28	NMV 800-200	800	200	1500
29	NMV 800-240	800	240	1500
30	NMV 800-280	800	280	1500
31	NMV 800-320	800	320	1500
32	NMV 1250-110	1250	110	1500
33	NMV 1250-165	1250	165	1500
34	NMV 1250-220	1250	220	1500
35	NMV 1250-275	1250	275	1500
36	NMV 1250-330	1250	330	1500
37	NMV 1800-110	1800	110	1500
38	NMV 1800-165	1800	165	1500
39	NMV 1800-220	1800	220	1500
40	NMV 1800-275	1800	275	1500

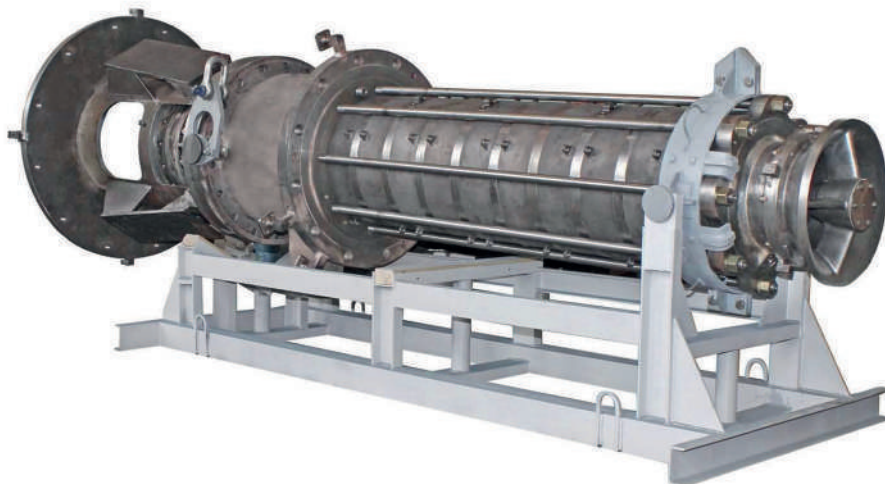

CNSn Series Horizontal Multistage Segmental

Designed for transporting crude oil and end products through long-distance, process and auxiliary pipelines.

Electrically driven horizontal multistage segmental centrifugal pumps, with all impellers facing the same way and automatic balancing of the rotor axial thrust by balance disc and balance disc seat. The suction nozzle horizontally sideward, the discharge nozzle vertically to the top. Radial forces and unbalanced axial thrust load of the pump rotor are taken up by the grease-lubricated antifriction bearings.

Shaft sealing: by dual mechanical seals or single mechanical seals, each provided with an auxiliary (safety) seal on the atmosphere side. Cartridge type design of the mechanical seals allows their installation and removal as an assembly unit.

Cyclone separators for cleaning liquid supplied to the mechanical seal chambers can be mounted on the pumps for their reliability improvement.

For applications with low NPSH available existing at the installation, the CNSn 500 model pumps can be equipped with an inducer to ensure NPSH required equal to 3 m.

Made in compliance with Transneft's General and Specific Engineering Requirements (OTT and STT resp.).



CNSn500

Nos	Pump make	Capacity, m ³ /h	Head, m	Rotational speed (synchr.), rpm	Motor nominal power, kW
1	CNSn 315-126	315	126	1500	200
2	CNSn 315-189	315	189	1500	250
3	CNSn 315-252	315	252	1500	315
4	CNSn 315-315	315	315	1500	400
5	CNSn 315-378	315	378	1500	450
6	CNSn 315-441	315	441	1500	630
7	CNSn 315-504	315	504	1500	630
8	CNSn 315-567	315	567	1500	800
9	CNSn 315-630	315	630	1500	800
10	CNSn 500-160	500	160	1500	400
11	CNSn 500-240	500	240	1500	630
12	CNSn 500-320	500	320	1500	800
13	CNSn 500-400	500	400	1500	1000
14	CNSn 500-480	500	480	1500	1000
15	CNSn 500-560	500	560	1500	1250
16	CNSn 500-640	500	640	1500	1600
17	CNSn 500-720	500	720	1500	1600
18	CNSn 500-800	500	800	1500	2000
19	CNSn 500-880	500	880	1500	2000

Coverage Chart of the Pipeline Pumps CNSn

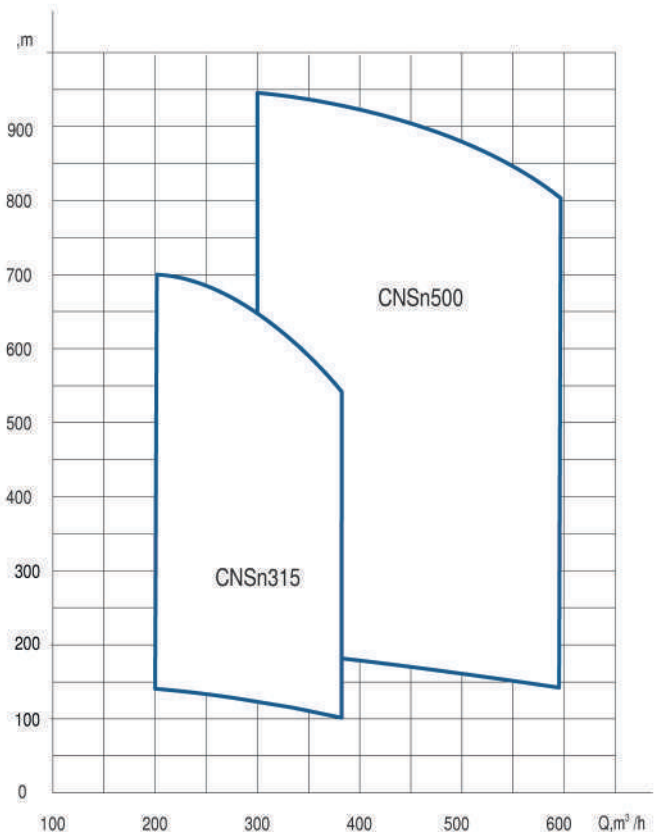

AMG Series pumps: Horizontal, centrifugal, multistage, between bearings, axial split casing pumps.

The pumps are used for waterflooding of oil-bearing formations, pumping of crude oil, pipeline transportation of oil, petroleum products, and liquefied hydrocarbon gas, pumping of supercritical ethylene and carbon dioxide. Pumps (type BB3 according to API 610 / ISO 13709) are among the most widely used in the oil and gas industry for the production of oil, gas and gas condensate onshore and offshore. The pumps are widely used in crude oil supply systems, vaporization plants, amine recovery plants in gas and oil refineries, petrochemical plants. This is the most common type of pump used in systems for emergency feedwater supply to nuclear power plant reactors and for condensate pumping, as well as in start-up systems for supplying feedwater to boilers of Thermal Power Plants.

Nos	Pump make	Design of the flow part	Capacity, m ³ /h	Head, max, m	Head, min, m	Rotational speed (sinchr.), rpm
1	AMG 80	Min	40	1300	200	3000
		Max	130	1300	200	3000
2	AMG 100	Min	140	1500	200	3000
		Max	270	1500	200	3000
3	AMG 150	Min	300	1500	250	3000
		Max	550	1500	250	3000
4	AMG 200	Min	600	1300	250	3000
		Max	850	1300	250	3000
5	AMG 250	Min	900	1200	250	3000
		Max	1500	1200	250	3000

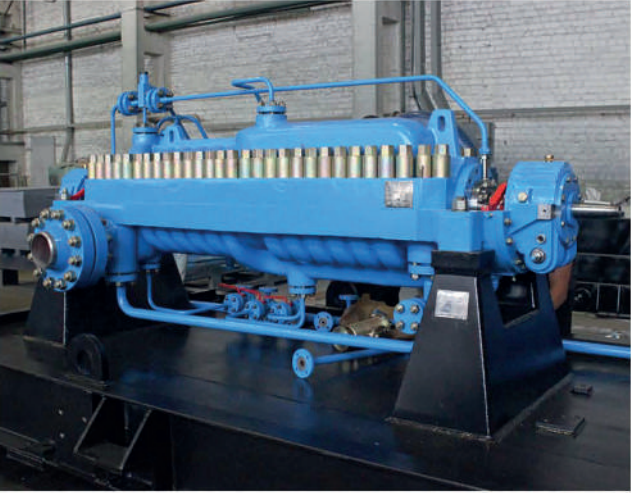

AMG 80L

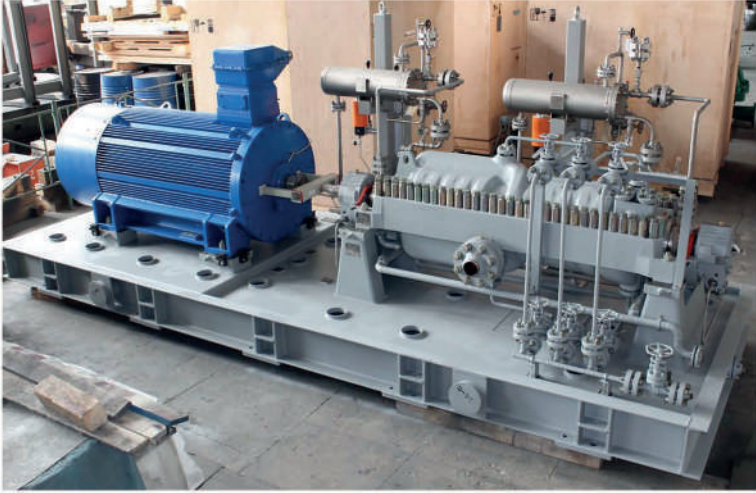

AMG 100 L

Coverage Chart for the AMG Series Pumps

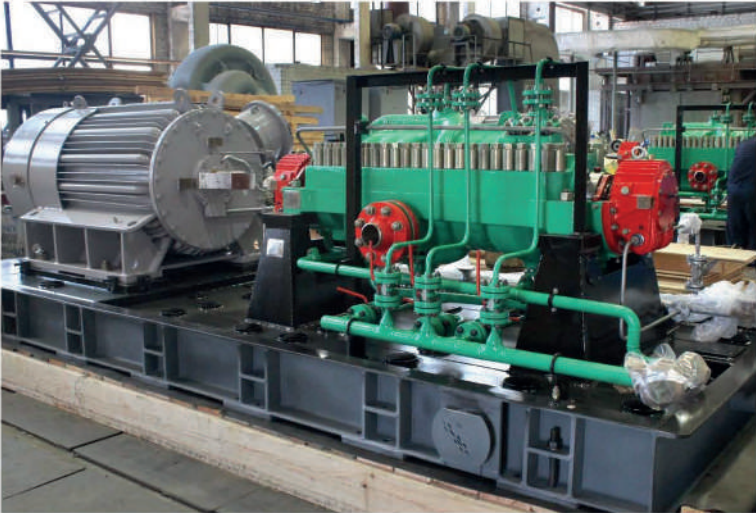
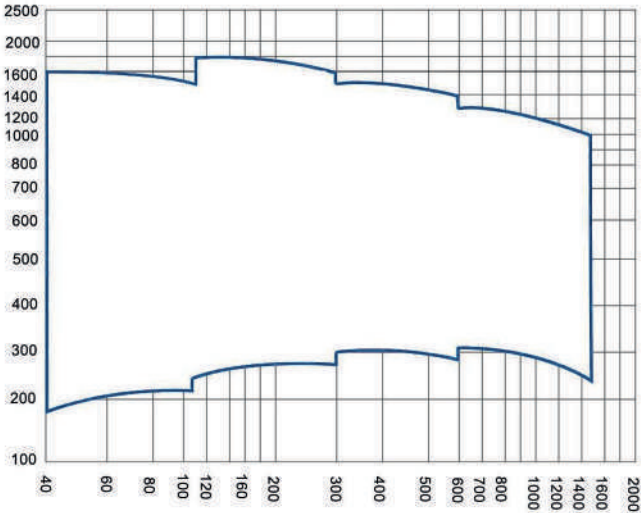

AMG 100H

20 ND_sN-M Model Double Flow Axially Split



20 ND_sN-M

Designed for delivering crude oil to the main pipeline pumps as booster pumps to ensure their cavitation-free operation. Suitable also as a loading pump for filling light products into tank wagons at the refineries and as an oil transfer pump in the tank farms.

Electrically driven, horizontal foot-mounted, between-bearings, single-stage, axially split volute casing centrifugal pump with a double entry radial impeller. The rotor is carried by grease-lubricated spherical roller bearings. Shaft sealing: mechanical seals with organized leakage drain

Nos	Pump make	Capacity, m ³ /h	Head, m	Rotational speed (synchr.), pm	Motor nominal power, kW
1	20ND _s N-M	2200	45	750	315

Coverage Chart of the Loading / Booster Pipeline Pumps NCN-E and 20 ND_sN-M

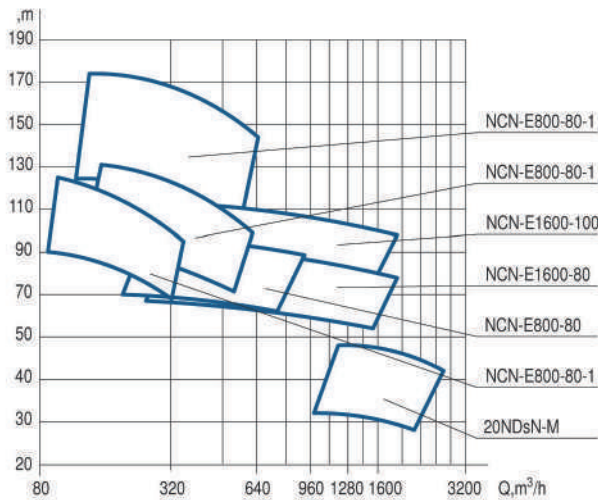

NCN-E Series Double Flow Axially Split

Applications (see Table below):

- Items 1 to 3: for boosting the pressure of oil-field produced (formation) water to be injected into the petroliferous pools (for secondary oil recovery) as booster waterflood pumps;

- Item 4: for handling triethylene glycol;

- Items 5, 7 to 9: for loading mazout (fuel oil) and light oil (motor gasoline, kerosene and diesel fuel) into tank wagons at the oil refinery terminals. May be used as booster pipeline pumps for NM series pipeline pumps used for handling crude oil;

- Item 10: for drawing off crude oil from the flow tanks (oil treating vessels) of the central process facility.

Electrically driven, horizontal foot- or semicentreline-mounted, between-bearings, single-stage, axially split volute casing centrifugal pumps with a double entry radial impeller. The rotor is carried by the grease-lubricated or oil-bath lubricated antifriction bearings. Shaft sealing: by mechanical seals.

Nos	Pump make	Capacity, m ³ /h	Head, m	Rotational speed (synchr.), pm	Motor nominal power, kW
1	NCN-E 800/0,6-80-1	341	101.6	3000	160
2	NCN-E 800-80-1	567	106	3000	315
3	NCN-E 800-80-1	571	150.4	3000	400
4	NCN-E 800-80a-1	618	136.5	3000	400
5	NCN-E 800-80	800	80	1500	315
6	NCN-E 800-80	808	90.4	1500	315
7	NCN-E 1600-80	1600	80	1500	630
8	NCN-E 1600-80	1800	70	1500	630
9	NCN-E 1600-100	1600	100	1500	630
10	NCN-E 1600-100	1487	111	1500	800



NCN-E

NG Model Double Flow Axially Split / Radially Split Barrel

The fuel oil charge pump **NG 800-250** is designed for delivering fuel oil (a heavy pyrolysis tar) into the high-pressure polyethylene production plants.

Electrically driven horizontal single-stage axially split volute casing centrifugal pump with a double entry impeller. The pump rotor is carried by the plain bearings with forced oil lubrication. Shaft sealing: by mechanical seals

The tower bottoms pump **NG 200-510** is designed for handling tar (asphalt flux removal) in the slow coking process units at the petroleum refineries.

Electrically driven horizontal multistage ring-section barrel-insert centrifugal pump. The pump rotor is carried by the pressure oil lubricated plain bearings. Shaft sealing: by mechanical seals

The pumps **NG 200-510** and **NMF 200-600** are designed for handling tar (asphalt flux removal) in the slow coking process units and other oil products at the temperature of 400°C.



Nos	Pump make	Capacity, m ³ /h	Head, m	Rotational speed (synchr.), pm	Motor nominal power, kW
1	NG 200-510	182	410	3000	400
2	NG 200-510	200	510	3000	400
3	NG 800-250	800	250	3000	1000
4	NMF 200-600	200	600	3000	500

Coverage Chart of the Fuel Oil Charge & Tower Bottoms Pumps NH

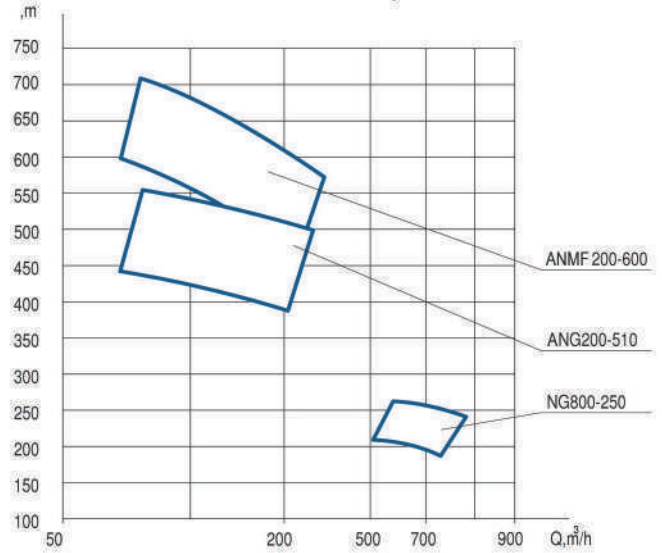

HB Series Radially Split Barrel

Designed for handling aqueous solutions of mono- or diethanolamines in the plants for cleaning of natural gas from hydrogen sulphide and carbon dioxide.

Electrically driven, horizontal, between-bearings, barrel-insert centrifugal pump with single entry radial impellers. The pump rotor is carried by the pressure lubricated plain bearings. Shaft sealing: mechanical seals

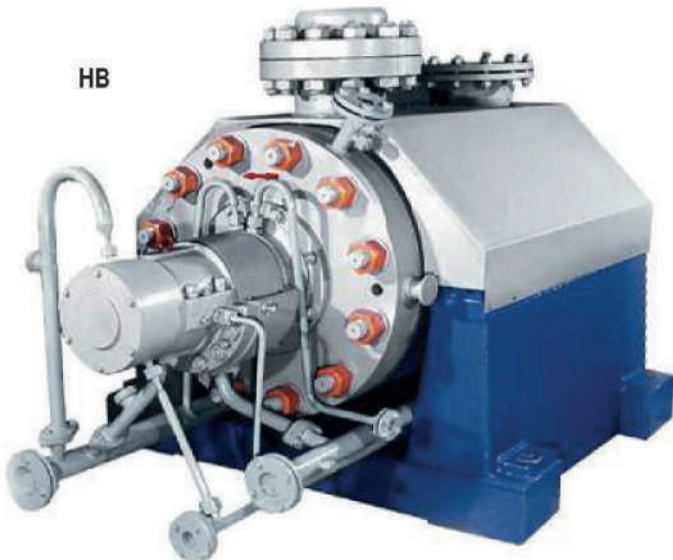

Nos	Pump make	Capacity, m ³ /h	Head, m	Rotational speed (synchr.), pm	Motor nominal power, kW
1	HB 450-650	450	650	3000	1250
2	HB 500-650	500	650	3000	1250
3	HB 800-610	800	610	3000	2000
4	HB 1050-650	1050	650	3000	2500
5	HBE-M630-390	630	390	1500	1250

Coverage Chart of the Chemical Pumps HB

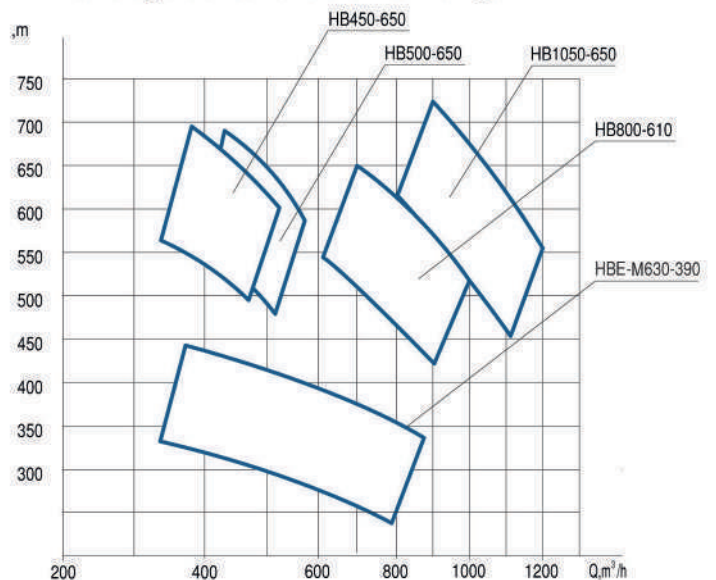

CNS Series Multistage Segmental

Designed for creating high pressure (up to 250 bar) in various technological and production systems. They have become most widespread in systems of artificial pressure increase (PPD) during oil production in oil fields, where they are used to pump water into oil-bearing formations. They are also used to beat down scale with water at rolling mills of metallurgical plants (combinations).

CNS pumps – centrifugal, horizontal, multi-stage, single-body, sectional type; variations of constructive designs are described below.

HP, GP pumps are multistage centrifugal pumps of a new generation, designed to replace CNS and CNSp pumps. They provide interchangeability in terms of pumping technology and the size of the connection to the foundation and pipelines. Designed in accordance with the requirements of international industry standards; have improved efficiency and reliability.



CNS...-2 models

The pump rotor is carried by the oil-bath or pressure oil lubricated plain bearings. Shaft sealing: soft packed glands (C) or mechanical seals (T). The suction nozzle horizontally sideward, the discharge nozzle vertically to the top.



CNSz...-2 models

In order to enhance a cumulative reliability and entire life of the pumps if frequently started and stopped, their design features a balance disc-from-seat separation device. It is intended for ensuring the guaranteed axial gap between the balance disc and balance disc seat.



CNSp.. models

With back-to-back impeller arrangement that makes an axial thrust balancing device unnecessary in the pump design and significantly improves the reliability of pump operation. The residual axial thrust is absorbed by a thrust bearing. The CNSp pumps are interchangeable with the CNS...-2 pumps in foundation connection dimensions.

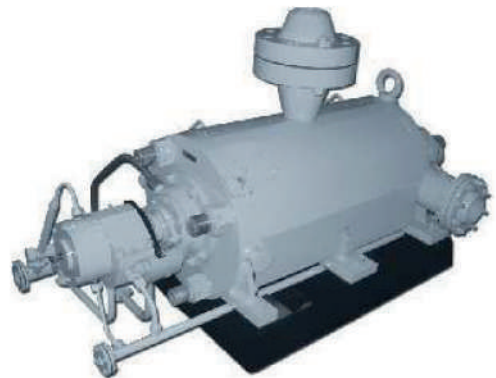

CNS...-3 models

The pump rotor is supported by bearings made of carbide materials built into the pump casing, which are lubricated and cooled by the pumped medium.

The end seals are mechanical. The CNS...-3 pumps are interchangeable with the CNS...-2 pumps in terms of connection dimensions to the foundation and pipelines.



CNS Series Multistage Segmental

Ordinary (general service) version

Handled media: clean water and oil-field produced waters free from hydrogen sulfide

Corrosion-resistant material construction

Handled media in case of corrosion-resisting and wear- and corrosion-resisting constructions: aggressive sewage and formation oil-field produced waters including those that contain hydrogen sulfide

Duplex steel construction

Handled media in case of duplex steel construction: aggressive sewage and formation and cenomanian oil-field produced waters including those that contain hydrogen sulfide (H₂S up to 400mg/l)

The Manufacturer shall select appropriate material construction according to handled medium characteristics specified by the Purchaser.

Unless otherwise specified, applicable to all the constructions:

* – only the CNSp models;

** – to all the pump models except CNSp;

*** – only the CNS ...-2 (2nd upgrading) models

Nos	Pump make	Capacity, m ³ /h	Head, m	Rotational speed (synchr.), pm	Motor nominal power, kW
1	CNS 10-200	10	200	3000	22
2	CNS 10-480	10	480	3000	55
3	CNS 10-700	10	700	3000	90
4	CNS 30-800	30	800	3000	315
5	CNS 30-1050	30	1050	3000	315
6	CNS 30-1422	30	1250	3000	315
7	CNS 40-800	40	800	3000	315
8	CNS 40-1050	40	1050	3000	315
9	CNS 40-1422	40	1250	3000	315
10	CNS 45-700	45	700	3000	315
11	CNS 45-900	45	900	3000	315
12	CNS 45-1050	45	1050	3000	500
13	CNS 45-1150	45	1150	3000	500
14	CNS 45-1275	45	1275	3000	500
15	CNS 45-1422	45	1422	3000	630
16	CNS 45-1525	45	1525	3000	630
17	CNS 45-1650	45	1650	3000	630
18	CNS 45-1775	45	1775	3000	800
19	CNS 45-1900	45	1900	3000	800
20	CNS 45-2100*	45	2100	3000	800
21	CNS 63-700**	63	700	3000	500
22	CNS 63-900	63	900	3000	500
23	CNS 63-1050	63	1050	3000	500
24	CNS 63-1150	63	1150	3000	500
25	CNS 63-1275	63	1275	3000	630
26	CNS 63-1422	63	1422	3000	630
27	CNS 63-1525	63	1525	3000	630
28	CNS 63-1650	63	1650	3000	800
29	CNS 63-1775	63	1775	3000	1000
30	CNS 63-1900	63	1900	3000	1000
31	CNS 63-2100*	63	2100	3000	800
32	CNS 90-700**	90	700	3000	500
33	CNS 90-900	90	900	3000	500
34	CNS 90-1050	90	1050	3000	630
35	CNS 90-1150	90	1150	3000	630
36	CNS 90-1275	90	1275	3000	630

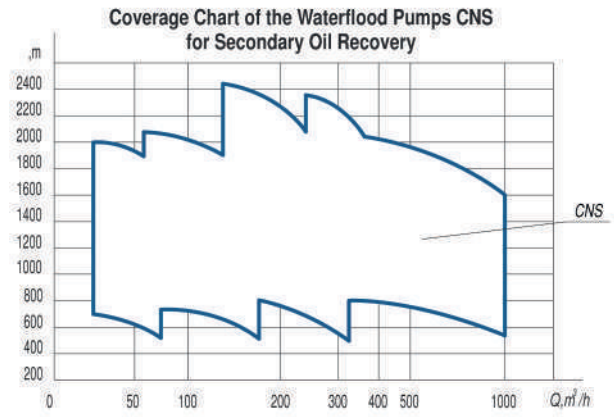

37	CNS 90-1422	90	1422	3000	800
38	CNS 90-1525	90	1525	3000	800
39	CNS 90-1650	90	1650	3000	800
40	CNS 90-1775	90	1775	3000	1000
41	CNS 90-1900	90	1900	3000	1000
42	CNS 90-2100*	90	2100	3000	1000
43	CNS 120-750**	120	700	3000	800
44	CNS 120-900	120	900	3000	1000
45	CNS 120-1050	120	1050	3000	1000
46	CNS 120-1150	120	1150	3000	1000
47	CNS 120-1275	120	1275	3000	1000
48	CNS 120-1422	120	1422	3000	1250
49	CNS 120-1525	120	1525	3000	1250
50	CNS 120-1650	120	1650	3000	1600
51	CNS 120-1775	120	1775	3000	1600
52	CNS 120-1900	120	1900	3000	1600
53	CNS 120-2100*	120	2100	3000	1250
54	CNS 180-700**	180	700	3000	800
55	CNS 180-900	180	900	3000	800
56	CNS 180-1050	180	1050	3000	100
57	CNS 180-1150	180	1150	3000	1000
58	CNS 180-1275	180	1275	3000	1000
59	CNS 180-1422	180	1422	3000	1250
60	CNS 180-1525	180	1525	3000	1250
61	CNS 180-1650	180	1650	3000	1600
62	CNS 180-1775	180	1775	3000	1600
63	CNS 180-1900	180	1900	3000	1600
64	CNS 180-2100*	180	2100	3000	1600
65	CNS 200-2050**	200	2050	3000	1600
66	CNS 200-2200**	200	2200	3000	2000
67	CNS 240-700**	240	700	3000	800
68	CNS 240-900	240	900	3000	1000
69	CNS 240-1050	240	1050	3000	1000
70	CNS 240-1150	240	1150	3000	1250
71	CNS 240-1275	240	1275	3000	1250
72	CNS 240-1422	240	1422	3000	1250
73	CNS 240-1525	240	1525	3000	1600
74	CNS 240-1650	240	1650	3000	1600
75	CNS 240-1775	240	1775	3000	1600
76	CNS 240-1900	240	1900	3000	2000
77	CNS 240-2100*	240	2100	3000	2000
78	CNS 315-1050	315	1050	3000	1600
79	CNS 315-1422	315	1422	3000	2000
80	CNS 315-1900	315	1900	3000	2500

CNS Series Multistage Segmental

81	CNS 500-1050	500	1050	3000	2500
82	CNS 500-1422	500	1422	3000	3150
83	CNS 500-1900	500	1900	3000	4000
84	CNS 630-1050	630	1050	3000	2500
85	CNS 630-1422	630	1422	3000	3150
86	CNS 630-1900	630	1900	3000	4000
87	CNS 720-1050	720	1050	3000	2500
88	CNS 720-1422	720	1422	3000	3150
89	CNS 720-1900	720	1900	3000	4000
90	CNS 300-1800***	300	1575	3000	3150
91	CNS 300-1800***	300	1800	3000	3150
92	CNS 360-2000***	360	2000	3000	3150
93	CNS 360-2000***	250	2370	3000	2500
94	CNS 360-2000***	341	1891	3000	3150
95	CNS 500-1900***	500	1900	3000	5000
96	CNS 500-1900***	567	2000	3000	5000
97	CNS 500-1900-1****	800	1390	3000	5000
98	CNS 630-1700***	630	1700	3000	4000



CNS (Dp) Radially Split Barrel



Designed for injection of water into the petroliferous pools to maintain the seam pressure for the intensification of production of oil, gas and condensate.

Due to its super duplex steel hydraulic parts suitable to handle highly-corrosive seawater, aggressive sewage and formation (oil-field produced) waters including those that contain hydrogen sulfide (H_2S up to 400 mg/l) with pH value of 4 to 9, density up to 1180 kg/m³ and maximum grain size of 0.2 mm at pumping temperatures ranging from 0 to +90 °C. The pump can be also used in the high pressure oil refining processes and petrochemical industry applications.

Motor driven, horizontal centerline-mounted, radially split multistage double-casing centrifugal pump with a withdrawable cartridge of ring-section type (BB5 type according to ANSI/API Standard 610 (ISO 13709:2009)). Two groups of single suction impellers rotating in opposite directions are arranged back-to-back with a cross-over to balance the rotor axial thrust.

The pump rotor is carried by two forced oil lubricated tilting-segment radial plain bearings.

The residual axial thrust of the rotor is taken up by the double(-acting) thrust plain bearing with tilting pads.

Shaft sealing: by single or dual mechanical seals of cartridge type. In the latter case: equipped with a life-support system. Nozzles vertically to the top

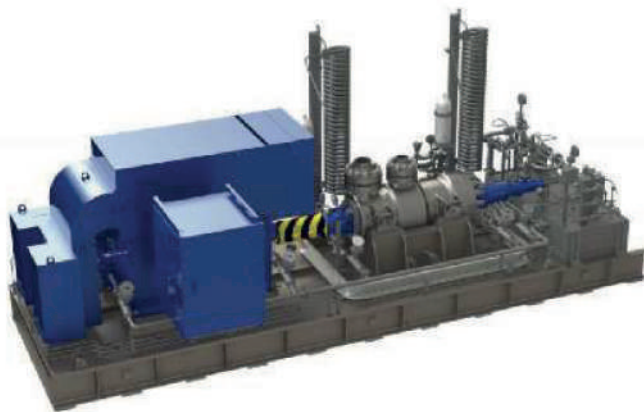

Development and mastering the production of ACNSDp series pumps is underway for covering models (duties) to deliver respectively 45, 63, 90, 120, 180, 240, 315, 630 and 720 m³/h.

BBH2

Vacuum water-ring pumps of ABBH2 model are designed for pumping of air, inert gases, steam and vapor-gas mixtures preliminary cleaned from mechanical contaminants. The pumps are supplied to mining and processing plants to improve the efficiency of the ore dressing process.

Pump make	Capacity		Working pressure Mbar	Motor nominal power, kW	Rotational speed, rpm
	m ³ /h	m ³ /min			
BBH2-50	3000	50	200	110	600
BBH2-150	8100	135	200	315	300
BBH2-300	19200	320	200	630	250

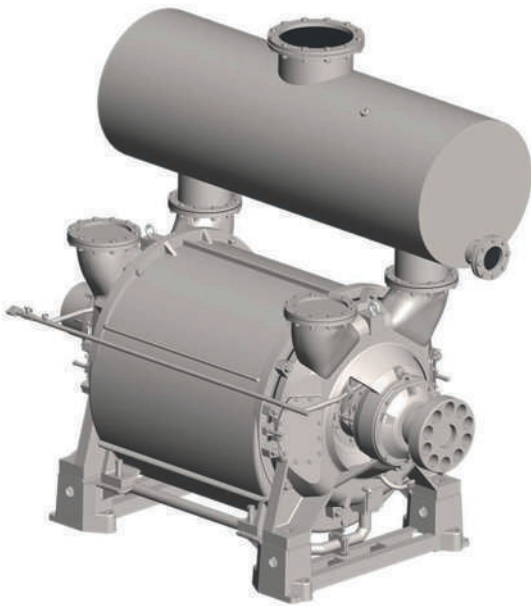

BBH2-150



BBH2-300

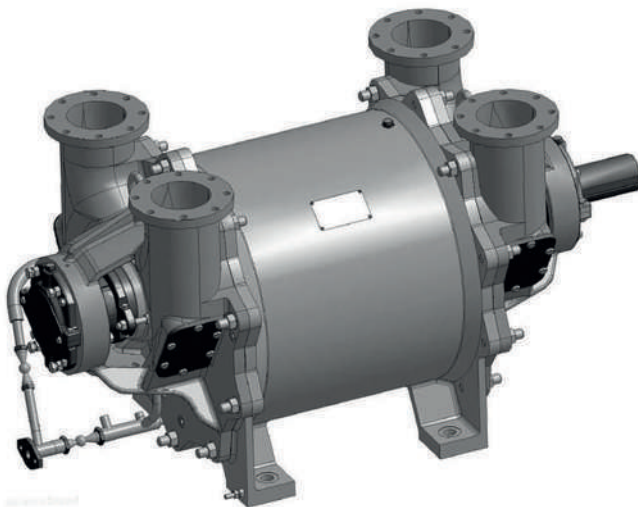

BBH2-50



BBH2-300

AVZ, NVZ & AVPI Series Oil-Sealed Plunger Vacuum

Slide-valve controlled vacuum pumps NVZ and pumping sets AVZ as well as plunger vacuum pumping sets AVPI are designed for evacuation of air, non-corrosive vapors and gas-vapor mixtures out of the closed hermetically sealed vacuum systems.

The pump units are economical and are widely used in various industries: machine-building, metallurgy, electrical engineering, electronic industry, for the production of foodstuffs, microbiologic specimens, medicines and in other branches of industry. Suitable as backing pumps for high vacuum plants

The **AVPI** series vacuum pumping sets are mostly efficient: for drying electrical engineering products, for the use in the production of building materials, in the drying and evaporator systems.

The **NVZ** pumps and **AVZ** series pumping sets can run at the ambient temperatures within plus 10°C to 35°C.

The pumping sets **AVPI-25**, **2AVPI-30**, **AVPI-90T** and **AVPI-180T** may be operated under roof at the ambient temperatures within minus 5°C to plus 35°C.

AVZ-20D, **AVPI-25**, **2AVPI-30** are air-cooled, the rest of pumping sets are water-cooled.

Oil tank of **2AVPI-30**, **AVPI-90T** and **AVPI-180T** has a built-in filter for cleaning exhaust gases from oil mist.

The pumping set **2AVPI-30** features a lubrication system that enables its operation in a wide range of inlet pressures.

The pumping set **AVPI-380** has a lubrication system that rules out the possibility of ingress of dirty working oil inside the bearings.

AVPI-380 has been designed for the replacement of NVZ-300.

AVPI-25 and **2AVPI-30** have been designed for the replacement of **AVZ-20D** in the production facilities where the development of high vacuum is not required.



AVZ-20D



AVZ-180



NVZ-500

Nos	Pump unit / pump make	Pumping speed, l/s	Ultimate residual pressure, kPa (mm Hg), not more	Nominal power of the motor, kW
1	AVZ-20D	20	1.1 10 ⁻³ (8 10 ⁻³)	2.2
2	AVPI-25	25	6.7 10 ⁻³ (5 10 ⁻²)	3
3	2AVPI-30	25	6.7 10 ⁻³ (5 10 ⁻²)	3
4	AVZ-63D	63	6.7 10 ⁻⁴ (5 10 ⁻³)	7.5
5	AVZ-90	90	6.7 10 ⁻³ (5 10 ⁻²)	11
6	AVPI-90	90	6.7 10 ⁻³ (5 10 ⁻²)	11
7	AVZ-125D	125	6.7 10 ⁻⁴ (5 10 ⁻³)	15
8	AVZ-180	180	6.7 10 ⁻³ (5 10 ⁻²)	15
9	AVZ-180	180	6.7 10 ⁻³ (5 10 ⁻²)	18.5
10	AVPI-180	180	6.7 10 ⁻³ (5 10 ⁻²)	15
11	AVPI-380	380	6.7 10 ⁻³ (5 10 ⁻²)	37
12	NVZ-500	560	6.7 10 ⁻³ (5 10 ⁻²)	55

Oil Mist Separator Filters

The oil mist filter FV-650 is designed for cleaning exhausted gas medium (air) from oil mist at the outlet of vacuum pumps with maximum pumping speed of 650 m³/h (180 l/s).

Nos	Filter make	Applied in (pump makes)	Maximum filter capacity, m ³ /h (l/s)	Filter fineness, %, not less
1	FV-650	VZ-125D, AVZ-180	650 (180)	80

HUM ELIT OIL

infopump@elit-oil.com.ua

info@humelitoil.com

www.humelitoil.com

2025-01

